

PRACTICE EXAM 7: SIMULATION (50 QUESTIONS)

Time: Two sessions of 60 minutes each (recommended)

Total questions: 50

Calculator and EQAO Grade 9 formula sheet permitted.

1. Solve for x in the equation $7 - 2x = -5$.

- A. -6
- B. 1
- C. -1
- D. 6

2. What is the surface area of a sphere with a radius of 3 cm, expressed in terms of π ? ($S = 4\pi r^2$.)

- A. $12\pi \text{ cm}^2$
- B. $9\pi \text{ cm}^2$
- C. $36\pi \text{ cm}^2$
- D. $108\pi \text{ cm}^2$

3. Which list is ordered correctly from least to greatest: 0.6, $\frac{5}{8}$, and 62%?

- A. $\frac{5}{8}$, 62%, 0.6
- B. 0.6, 62%, $\frac{5}{8}$
- C. 62%, 0.6, $\frac{5}{8}$

D. 0.6, $\frac{5}{8}$, 62%

4. A bag contains 5 red, 3 blue, and 2 green marbles. What is the probability of drawing a blue marble at random?

A. $\frac{3}{10}$

B. $\frac{1}{3}$

C. $\frac{3}{7}$

D. $\frac{1}{2}$

5. Solve the system $2x + y = 11$ and $x - y = 1$. What is the value of x ?

A. 3

B. 4

C. 5

D. 7

6. Which is the better value: a 750 g box of cereal for \$4.50, or a 1.2 kg box for \$6.60?

A. 1.2 kg box, at \$5.50 per kg

B. 750 g box, at \$5.50 per kg

C. 1.2 kg box, at \$6.00 per kg

D. both cost the same per kilogram

7. The perimeter of a rectangle is given by $P = 2l + 2w$. If $P = 36$ cm and the length $l = 11$ cm, what is the width w ?

A. 14 cm

B. 25 cm

- C. 18 cm
- D. 7 cm

8. Simplify the expression $(2^3)^2 \times 2$.

- A. 64
- B. 32
- C. 128
- D. 256

9. Two similar triangles have corresponding sides in the ratio 3 : 5. If a side of the smaller triangle is 12 cm, what is the length of the corresponding side of the larger triangle?

- A. 7.2 cm
- B. 15 cm
- C. 20 cm
- D. 36 cm

10. The variable y varies directly with x , and $y = 18$ when $x = 6$. What is the value of y when $x = 10$?

- A. 22
- B. 24
- C. 28
- D. 30

11. Look at the scatter plot below with its line of best fit. Using the line, what is the predicted value of y when $x = 6$?

[Figure PQ-1: Clean black-line technical scatter plot on a white background.]

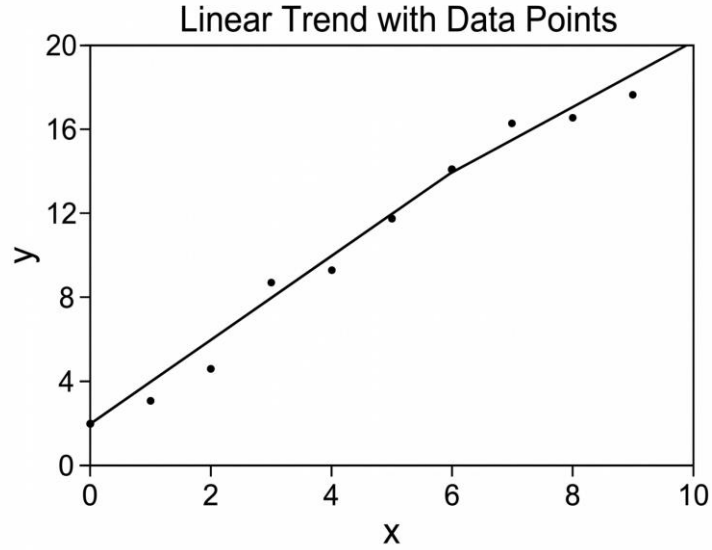

- A. 14
- B. 12
- C. 8
- D. 16

12. Simplify the expression $5a + 3b - 2a + 4b$.

- A. $10ab$
- B. $3a + 7b$
- C. $7a + 3b$
- D. $3a - 7b$

13. Evaluate the expression $-8 + 3 \times (-4) - (-6)$.

- A. -14
- B. -26
- C. 14
- D. -2

14. If $a = 3$ and $b = -2$, what is the value of the expression $2a^2 - b^3$?

- A. 10
- B. 22
- C. 26
- D. 14

15. Two angles of a triangle measure 47° and 68° . What is the measure of the third angle?

- A. 115°
- B. 65°
- C. 75°
- D. 55°

16. A jacket costs \$80 before tax. With 13% HST applied, what is the total cost?

- A. \$93.00
- B. \$80.13
- C. \$10.40
- D. \$90.40

17. Solve for x in the equation $(x - 3)/2 = 5$.

- A. 7
- B. 10
- C. 8
- D. 13

18. Consider the data set 4, 7, 7, 9, 12, 7, 15. What is the mode of this data set?

- A. 7
- B. 9
- C. 8.71
- D. 11

19. Express the number 0.00045 in scientific notation.

- A. 4.5×10^4
- B. 45×10^{-5}
- C. 4.5×10^{-4}
- D. 4.5×10^{-3}

20. Solve for x in the proportion $5/x = 15/24$.

- A. 6
- B. 8
- C. 72
- D. 9

21. A cone has a radius of 6 cm and a height of 7 cm. What is its volume, to the nearest whole number?
($V = (1/3)\pi r^2 h$, use $\pi \approx 3.14$.)

- A. 791 cm³
- B. 264 cm³
- C. 132 cm³
- D. 88 cm³

22. What is the slope of the line passing through the points $(-1, 4)$ and $(3, -8)$?

- A. 3
- B. $-1/3$
- C. -3
- D. $1/3$

23. A spinner has 8 equal sections numbered 1 to 8. What is the probability of spinning a number greater than 5?

- A. $5/8$
- B. $1/2$
- C. $1/4$
- D. $3/8$

24. Evaluate the expression $(5 - 2)^2 + 4 \times 3 - 10$.

- A. 11
- B. 23
- C. 7
- D. 17

25. For the linear relation $y = 4x - 5$, what is the value of x when $y = 19$?

- A. 6
- B. 5
- C. 71
- D. 3.5

26. How long will it take \$1,000 to earn \$150 in simple interest at an annual rate of 5%? ($I = Prt$.)

- A. 1.5 years
- B. 5 years
- C. 2 years
- D. 3 years

27. Solve for x in the equation $2(x + 3) = 4x - 2$.

- A. 2
- B. 4
- C. -4
- D. 1

28. A right triangle has legs measuring 9 cm and 12 cm. What is the perimeter of the triangle?

- A. 21 cm
- B. 30 cm
- C. 36 cm
- D. 54 cm

29. A town's population grows from 250 to 310. What is the percent increase in population?

- A. 60%
- B. 19.4%
- C. 24%
- D. 30%

30. What is the midpoint of the line segment joining the points $(2, -3)$ and $(8, 5)$?

- A. $(5, 1)$
- B. $(6, 8)$
- C. $(3, 4)$
- D. $(10, 2)$

31. In a class of 30 students, 18 play soccer and 12 do not. What fraction of the class plays soccer?

- A. $12/30$
- B. $3/5$
- C. $2/5$
- D. $18/100$

32. What is the distance between the points $(1, 2)$ and $(4, 6)$?

- A. 7
- B. 25
- C. $\sqrt{7}$
- D. 5

33. What is the least common multiple (LCM) of 6 and 8?

- A. 2
- B. 48
- C. 14
- D. 24

34. A bacteria culture doubles every hour. Starting with 50 bacteria, how many bacteria are present after 3 hours?

- A. 150
- B. 400
- C. 300
- D. 200

35. A trapezoid has parallel sides of 10 cm and 14 cm and a height of 6 cm. What is its area? ($A = (1/2)(a + b)h$.)

- A. 72 cm^2
- B. 144 cm^2
- C. 84 cm^2
- D. 60 cm^2

36. On a test, 10 students scored an average of 70 and 5 students scored an average of 85. What is the average score of all 15 students?

- A. 77.5
- B. 70
- C. 75
- D. 80

37. Factor the trinomial $x^2 + 7x + 12$ completely.

- A. $(x + 2)(x + 6)$
- B. $(x + 3)(x + 4)$
- C. $(x + 1)(x + 12)$

D. $(x - 3)(x - 4)$

38. A salesperson earns a base of \$400 per week plus 5% commission on sales. In a week with \$6,000 in sales, what are the total earnings?

- A. \$300
- B. \$400
- C. \$6,300
- D. \$700

39. Between which two consecutive whole numbers does $\sqrt{54}$ lie?

- A. 5 and 6
- B. 6 and 7
- C. 7 and 8
- D. 8 and 9

40. Three consecutive integers have a sum of 72. What is the smallest of the three integers?

- A. 23
- B. 24
- C. 25
- D. 22

41. A data set has the values 14, 22, 9, 31, 18, 27. What is the range of the data set?

- A. 22
- B. 31
- C. 20.2

D. 18

42. Simplify the expression $(6x^2 + 9x) \div 3x$.

A. $2x^2 + 3$

B. $6x + 9$

C. $2x + 3$

D. $3x + 6$

43. A rectangular fish tank measures 50 cm long, 30 cm wide, and 40 cm high. What is its volume in litres? (1 L = 1,000 cm³.)

A. 120 L

B. 6 L

C. 600 L

D. 60 L

44. A sum of \$240 is shared between two people in the ratio 5 : 3. How much does the person with the larger share receive?

A. \$96

B. \$150

C. \$90

D. \$160

45. What is the x-intercept of the line $3x - 4y = 12$?

A. (0, -3)

B. (0, 4)

- C. (4, 0)
- D. (-3, 0)

46. A coin is flipped twice. What is the probability of getting two heads?

- A. $\frac{1}{2}$
- B. $\frac{1}{4}$
- C. $\frac{1}{3}$
- D. $\frac{3}{4}$

47. A \$250 bicycle is on sale for 30% off. What is the sale price?

- A. \$75
- B. \$220
- C. \$325
- D. \$175

48. In the diagram below, lines m and n are parallel and are cut by a transversal. The marked angle measures 110° . What is the measure of angle x ?

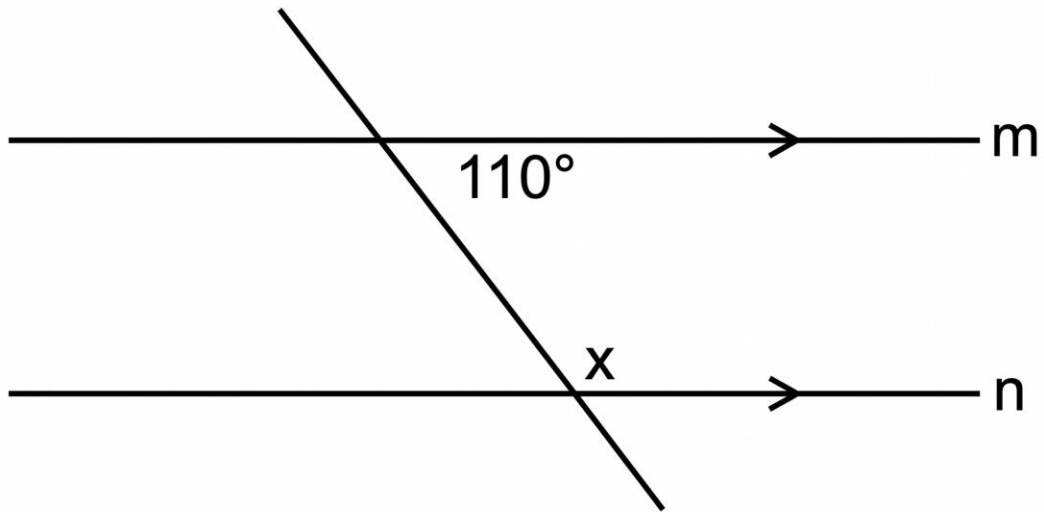

Figure PQ-2

- A. 110°
- B. 70°
- C. 90°
- D. 55°

49. A household spends \$1,800 of its \$4,500 monthly income on housing. What percentage of the income is spent on housing?

- A. 25%
- B. 40%
- C. 45%
- D. 36%

50. Evaluate the expression $3.6 \div 0.9 + 1.5 \times 2$.

- A. 5.4
- B. 9
- C. 11

Practice Exam 7: Answer Key and Full Explanations

- 1. D** — Isolate the variable term by subtracting 7 from both sides: $-2x = -12$. Dividing both sides by -2 gives $x = 6$. Dividing two negatives produces a positive result.
- 2. C** — Substitute the radius into the sphere surface-area formula $S = 4\pi r^2$: $S = 4\pi(3^2) = 4\pi(9) = 36\pi \text{ cm}^2$. The radius must be squared before multiplying by 4π .
- 3. B** — Convert each value to a decimal for comparison: $0.6 = 0.600$, $62\% = 0.620$, and $5/8 = 0.625$. Ordered from least to greatest, this is 0.6 , 62% , $5/8$. A common decimal form makes mixed number types directly comparable.
- 4. A** — Probability is favourable outcomes over total outcomes. There are 3 blue marbles out of $5 + 3 + 2 = 10$ total, giving $3/10$. The total must include marbles of every colour.
- 5. B** — Adding the two equations eliminates y because $+y$ and $-y$ cancel: $(2x + y) + (x - y) = 11 + 1$, giving $3x = 12$, so $x = 4$. Elimination works when opposite coefficients sum to zero.
- 6. A** — Compare unit prices per kilogram. The 750 g box: $\$4.50 \div 0.75 \text{ kg} = \$6.00/\text{kg}$. The 1.2 kg box: $\$6.60 \div 1.2 \text{ kg} = \$5.50/\text{kg}$. The larger box is cheaper per kilogram, making it the better value.
- 7. D** — Substitute the known values into $P = 2l + 2w$: $36 = 2(11) + 2w = 22 + 2w$. Subtracting 22 gives $2w = 14$, so $w = 7 \text{ cm}$. The length term is removed before isolating the width.
- 8. C** — Apply the power-of-a-power rule first: $(2^3)^2 = 2^6 = 64$. Then multiply by 2: $64 \times 2 = 128$, which is also 2^7 . Multiplying powers of the same base adds the exponents.
- 9. C** — In similar triangles, corresponding sides keep the same ratio. Scaling the 12 cm side by $5/3$ gives $12 \times 5/3 = 20 \text{ cm}$. The larger triangle's side must be longer because 5 exceeds 3.
- 10. D** — Direct variation means $y = kx$. Finding the constant: $k = 18 \div 6 = 3$. Then $y = 3 \times 10 = 30$. The constant of proportionality stays fixed across all value pairs.
- 11. A** — The line of best fit passes through $(0, 2)$ and $(6, 14)$, giving a slope of $(14 - 2)/(6 - 0) = 2$ and the equation $y = 2x + 2$. Substituting $x = 6$: $y = 2(6) + 2 = 14$. Reading directly off the line gives the predicted value.
- 12. B** — Combine like terms by grouping the a-terms and the b-terms separately: $5a - 2a = 3a$ and $3b + 4b = 7b$, giving $3a + 7b$. Unlike terms with different variables cannot be combined.
- 13. A** — Follow order of operations, doing multiplication first: $3 \times (-4) = -12$. Then $-8 + (-12) = -20$, and subtracting -6 means adding 6: $-20 + 6 = -14$. Subtracting a negative reverses to addition.

- 14. C** — Substitute and apply order of operations: $2(3^2) = 2(9) = 18$, and $(-2)^3 = -8$. Then $18 - (-8) = 18 + 8 = 26$. The cube of a negative stays negative, so subtracting it adds.
- 15. B** — The three interior angles of a triangle sum to 180° . Subtracting the two known angles: $180 - 47 - 68 = 65^\circ$. This angle-sum property holds for every triangle.
- 16. D** — Adding 13% tax means multiplying by 1.13: $80 \times 1.13 = \$90.40$. Multiplying by 1 plus the tax rate combines the base price and the tax in one step.
- 17. D** — Multiply both sides by 2 to clear the fraction: $x - 3 = 10$. Adding 3 gives $x = 13$. Clearing the denominator first simplifies the equation to one step.
- 18. A** — The mode is the value that appears most often. The number 7 occurs three times, more than any other value, so the mode is 7. The mode counts frequency, not size.
- 19. C** — Scientific notation expresses a number as a value between 1 and 10 times a power of ten. Moving the decimal point four places right to reach 4.5 means the exponent is -4 , giving 4.5×10^{-4} . A small number requires a negative exponent.
- 20. B** — Cross-multiply the proportion: $5 \times 24 = 15 \times x$, so $120 = 15x$. Dividing gives $x = 8$. Cross-multiplication converts a proportion into a solvable linear equation.
- 21. B** — Substitute into $V = (1/3)\pi r^2 h$: $(1/3)(3.14)(6^2)(7) = (1/3)(3.14)(36)(7) = (1/3)(791.28) \approx 264 \text{ cm}^3$. The one-third factor is what distinguishes a cone from a cylinder of equal base and height.
- 22. C** — Slope is the change in y over the change in x : $(-8 - 4)/(3 - (-1)) = -12/4 = -3$. A negative slope indicates the line falls from left to right.
- 23. D** — Numbers greater than 5 are 6, 7, and 8 — three favourable outcomes out of 8 equal sections, giving $3/8$. "Greater than 5" excludes 5 itself, so only three values qualify.
- 24. A** — Apply order of operations: the bracket first, $(5 - 2)^2 = 3^2 = 9$, then $4 \times 3 = 12$. Combining left to right: $9 + 12 - 10 = 11$. Brackets and exponents are resolved before addition.
- 25. A** — Substitute $y = 19$ into $y = 4x - 5$: $19 = 4x - 5$. Adding 5 gives $4x = 24$, so $x = 6$. Working backward from the output solves for the input.
- 26. D** — Rearrange $I = Prt$ to solve for time: $150 = 1,000 \times 0.05 \times t = 50t$. Dividing gives $t = 3$ years. The annual interest of \$50 must accumulate for three years to reach \$150.
- 27. B** — Expand the left side: $2(x + 3) = 2x + 6$. Setting $2x + 6 = 4x - 2$, subtract $2x$ and add 2 to get $8 = 2x$, so $x = 4$. Collecting variables on one side isolates the unknown.
- 28. C** — First find the hypotenuse using the Pythagorean theorem: $\sqrt{(9^2 + 12^2)} = \sqrt{(81 + 144)} = \sqrt{225} = 15$ cm. The perimeter is the sum of all three sides: $9 + 12 + 15 = 36$ cm.

- 29. C** — Percent increase compares the change to the original amount: the increase is $310 - 250 = 60$, and $60 \div 250 = 0.24 = 24\%$. The starting value, not the final value, is the base of the comparison.
- 30. A** — The midpoint averages the x-coordinates and the y-coordinates separately: $((2 + 8)/2, (-3 + 5)/2) = (5, 1)$. Each coordinate of the midpoint is the mean of the corresponding endpoint coordinates.
- 31. B** — The fraction compares soccer players to the whole class: 18 out of 30. Simplifying by dividing both by 6 gives $3/5$. The fraction must be reduced to lowest terms.
- 32. D** — Apply the distance formula: $\sqrt{(4 - 1)^2 + (6 - 2)^2} = \sqrt{3^2 + 4^2} = \sqrt{9 + 16} = \sqrt{25} = 5$. This is a 3-4-5 right-triangle relationship between the two points.
- 33. D** — The least common multiple is the smallest number divisible by both. Multiples of 8 are 8, 16, 24, and 24 is the first also divisible by 6, so the LCM is 24. The LCM is at least as large as the bigger number.
- 34. B** — Doubling each hour means multiplying by 2 raised to the number of hours: $50 \times 2^3 = 50 \times 8 = 400$. Repeated doubling is exponential growth, not simple addition.
- 35. A** — Substitute into the trapezoid area formula $A = (1/2)(a + b)h$: $(1/2)(10 + 14)(6) = (1/2)(24)(6) = 72 \text{ cm}^2$. The two parallel sides are averaged before multiplying by the height.
- 36. C** — A combined average weights each group by its size: $(10 \times 70 + 5 \times 85)/15 = (700 + 425)/15 = 1,125/15 = 75$. Simply averaging 70 and 85 would ignore the unequal group sizes.
- 37. B** — Find two numbers that multiply to 12 and add to 7: those are 3 and 4. The factored form is therefore $(x + 3)(x + 4)$. Checking by expansion confirms the middle term $7x$.
- 38. D** — Total earnings combine the fixed base with the commission: $400 + 0.05 \times 6,000 = 400 + 300 = \700 . The 5% commission applies only to the sales amount, not the base pay.
- 39. C** — Since $7^2 = 49$ and $8^2 = 64$, and 54 lies between 49 and 64, the value of $\sqrt{54}$ lies between 7 and 8. Identifying the nearest perfect squares brackets the irrational root.
- 40. A** — Represent the integers as $n, n + 1, n + 2$. Their sum is $3n + 3 = 72$, so $3n = 69$ and $n = 23$. The smallest integer is the base value n , which is 23.
- 41. A** — The range is the largest value minus the smallest value: $31 - 9 = 22$. The range measures the total spread of the data, ignoring the values in between.
- 42. C** — Divide each term in the numerator by $3x$: $(6x^2)/(3x) = 2x$ and $(9x)/(3x) = 3$, giving $2x + 3$. Dividing a polynomial by a monomial divides every term separately.
- 43. D** — Volume is length \times width \times height: $50 \times 30 \times 40 = 60,000 \text{ cm}^3$. Converting to litres by dividing by 1,000 gives 60 L. The capacity conversion is essential since the answer is requested in litres.

44. B — The ratio 5 : 3 has $5 + 3 = 8$ total parts. The larger share is $\frac{5}{8}$ of the total: $\frac{5}{8} \times 240 = \150 . Finding the value of all parts together comes before splitting.

45. C — The x-intercept occurs where $y = 0$. Substituting: $3x - 4(0) = 12$, so $3x = 12$ and $x = 4$, giving the point (4, 0). The x-intercept always has a y-coordinate of zero.

46. B — Each flip has a $\frac{1}{2}$ chance of heads, and the flips are independent, so the probabilities multiply: $(\frac{1}{2})(\frac{1}{2}) = \frac{1}{4}$. Independent events combine by multiplication, not addition.

47. D — A 30% discount means paying 70% of the original price: $250 \times 0.70 = \$175$. Multiplying by the retained percentage finds the sale price in one step.

48. A — When parallel lines are cut by a transversal, corresponding angles are equal. Since the marked angle and x sit in the same position at their respective intersections, $x = 110^\circ$. The parallel condition is what guarantees the angles match.

49. B — The percentage is the housing cost over total income: $1,800 \div 4,500 = 0.40 = 40\%$. Converting the decimal to a percent gives the share of income spent on housing.

50. D — Apply order of operations, doing division and multiplication before addition: $3.6 \div 0.9 = 4$ and $1.5 \times 2 = 3$. Then $4 + 3 = 7$. Both operations are completed before the final sum.