

# PRACTICE EXAM 6: FE ELECTRICAL AND COMPUTER SIMULATION (110 QUESTIONS)

---

**Time allotted: 5 hours 20 minutes**

**Materials: NCEES-approved calculator + NCEES FE Reference Handbook only**

1. What is the derivative of  $f(x) = \cos(x)$ ?

- A.  $\cos(x)$
- B.  $-\sin(x)$
- C.  $\sin(x)$
- D.  $-\cos(x)$

2. Evaluate the indefinite integral  $\int 2x \, dx$ .

- A. 2
- B.  $2x^2$
- C.  $x$
- D.  $x^2 + C$

3. Convert the angle  $2\pi/3$  radians to degrees.

- A.  $120^\circ$
- B.  $60^\circ$
- C.  $150^\circ$

D.  $90^\circ$

4. Find the magnitude of the resultant of two perpendicular vectors of lengths 6 and 8.

A. 14

B. 2

C. 10

D. 48

5. In the figure below, the right triangle has legs of 5 and 12. What is the length of the hypotenuse  $c$ ?

Figure PQ-1



A. 17

B. 13

C. 7

D. 60

6. Evaluate the limit  $\lim_{x \rightarrow 2} (x^2 - 4)/(x - 2)$ .

- A. 4
- B. 0
- C. 2
- D.  $\infty$

7. The Taylor series expansion of  $e^x$  about  $x = 0$  begins with which terms?

- A.  $1 - x + x^2/2 - \dots$
- B.  $x - x^3/6 + x^5/120 - \dots$
- C.  $1 - x^2/2 + x^4/24 - \dots$
- D.  $1 + x + x^2/2 + x^3/6 + \dots$

8. What is the period of the function  $f(x) = \sin(2x)$ ?

- A.  $4\pi$
- B.  $2\pi$
- C.  $\pi$
- D.  $\pi/2$

9. Find the inverse of the  $2 \times 2$  diagonal matrix  $[[2, 0], [0, 4]]$ .

- A.  $[[0.5, 0], [0, 0.25]]$
- B.  $[[2, 0], [0, 4]]$
- C.  $[[4, 0], [0, 2]]$
- D.  $[[0.25, 0], [0, 0.5]]$

10. Solve the differential equation  $dy/dx = x$  with the condition  $y(0) = 1$ .

- A.  $y = x + 1$
- B.  $y = x^2/2 + 1$
- C.  $y = x^2 + 1$
- D.  $y = 2x^2 + 1$

11. Evaluate the partial derivative  $\partial/\partial x$  of  $f(x, y) = 3x^2y + y^3$ .

- A.  $3x^2 + 3y^2$
- B.  $6xy + 3y^2$
- C.  $x^2y$
- D.  $6xy$

12. What is the gradient  $\nabla f$  of the scalar field  $f(x, y) = x^2 + y^2$ ?

- A.  $(2x, 2y)$
- B.  $(x^2, y^2)$
- C.  $(2, 2)$
- D.  $(x, y)$

13. A standard deck of 52 cards is shuffled. What is the probability of drawing a heart?

- A.  $1/52$
- B.  $1/2$
- C.  $1/4$
- D.  $1/13$

14. The probability of an event is 0.3. What is the probability that the event does NOT occur?

- A. 0.3
- B. 0.7
- C. 0.5
- D. 1.3

15. Two fair dice are rolled. What is the probability that the sum equals 7?

- A.  $1/12$
- B.  $1/36$
- C.  $5/36$
- D.  $1/6$

16. A data set has values 4, 8, 8, 10, 20. What is the median?

- A. 10
- B. 8
- C. 12
- D. 50

17. How many distinct arrangements (permutations) are there of the letters in the word "MATH"?

- A. 4
- B. 24
- C. 12
- D. 16

18. Under the NSPE Code of Ethics, the engineer's foremost obligation is to:

- A. Maximize profit for the engineer's employer or firm
- B. Advance the engineer's own professional reputation first
- C. Hold paramount the safety, health, and welfare of the public
- D. Complete every assigned project ahead of the deadline

19. An engineer is offered a consulting fee to certify a design the engineer believes is unsafe. Under the NSPE Code, the engineer should:

- A. Refuse to certify the design and decline to proceed with it
- B. Certify the design since the client accepts all liability
- C. Certify it but note private reservations in personal files
- D. Accept the fee and certify only the safe portions of it

20. Under the NSPE Code, accepting valuable gifts from suppliers seeking to influence engineering decisions is:

- A. Acceptable if the gift's value is fully disclosed afterward
- B. Acceptable provided the supplier is a long-standing partner
- C. Acceptable if the engineer's employer is also informed first
- D. A conflict of interest that engineers should not accept

21. An engineer asked to perform work outside their area of competence should:

- A. Limit services to areas of competence or associate with qualified experts
- B. Proceed independently to broaden their professional experience base
- C. Decline all such work permanently to avoid any possible liability
- D. Subcontract the entire project without informing the paying client

22. A loan of \$5,000 is taken at a nominal annual rate of 12% compounded monthly. What is the effective monthly interest rate?

- A. 1%
- B. 12%
- C. 0.12%
- D. 6%

23. An asset costs \$20,000 today and returns a single \$26,620 payment in 3 years. At 10% annual interest, what is its net present worth? Given  $(P/F, 10\%, 3) = 0.7513$ .

- A. +\$6,620
- B. -\$200
- C. +\$5,000
- D. 0

24. The capitalized cost of a perpetual annual expense of \$1,000 at an interest rate of 5% is:

- A. \$5,000
- B. \$50,000
- C. \$20,000
- D. \$1,050

25. A bond with a face value of \$1,000 pays an annual coupon of \$60. What is its coupon rate?

- A. 60%
- B. 6%
- C. 0.6%
- D. 16.7%

26. In a benefit-cost analysis, a public project is generally considered economically justified when the benefit-cost ratio is:

- A. Less than zero
- B. Equal to exactly zero
- C. Less than one
- D. Greater than or equal to one

27. The property of a material that quantifies its opposition to current flow per unit length and cross-section is its:

- A. Conductance
- B. Permittivity
- C. Resistivity
- D. Capacitance

28. Compared to conductors, insulators are characterized by:

- A. A large energy band gap between valence and conduction bands
- B. A partially filled conduction band at room temperature
- C. An abundance of free electrons available for conduction
- D. A negative temperature coefficient of conductivity always

29. The piezoelectric effect describes a material that:

- A. Changes resistance in response to incident light energy
- B. Emits photons when an electric current passes through it
- C. Generates a voltage when subjected to mechanical stress
- D. Stores magnetic energy when a current flows through it

30. A thermistor is a device whose resistance:

- A. Remains constant regardless of temperature changes
- B. Varies significantly and predictably with temperature
- C. Increases linearly with the applied voltage across it
- D. Depends only on the frequency of the applied signal

31. A 24 V source drives three  $12\ \Omega$  resistors connected in series. What is the total current drawn from the source?

- A. 0.667 A
- B. 2 A
- C. 6 A
- D. 0.5 A

32. Two resistors,  $3\ \Omega$  and  $6\ \Omega$ , are connected in parallel. What is the equivalent resistance?

- A.  $9\ \Omega$
- B.  $4.5\ \Omega$
- C.  $0.5\ \Omega$
- D.  $2\ \Omega$

33. In the circuit shown, find the total resistance seen by the source.

Figure PQ-2

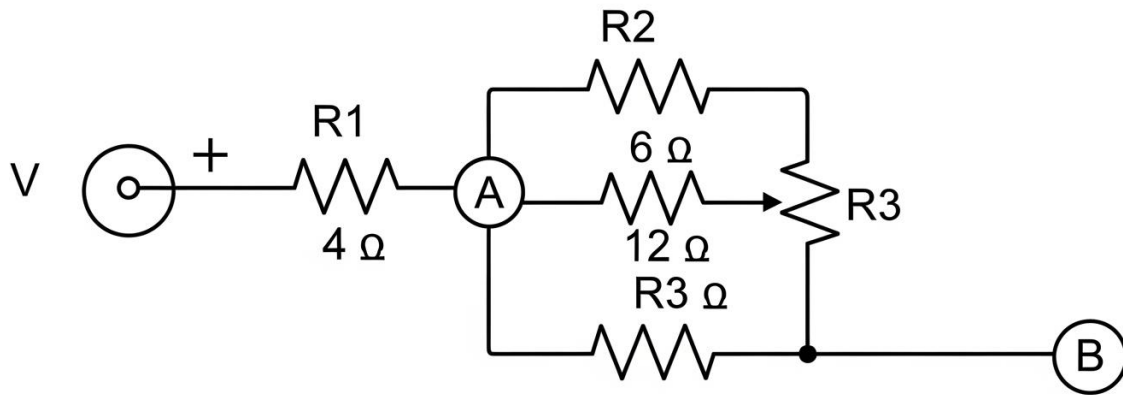

- A.  $22\ \Omega$
- B.  $8\ \Omega$
- C.  $16\ \Omega$
- D.  $4\ \Omega$

34. An AC voltage source  $v(t) = 100 \cdot \sin(377t)$  V is applied to a circuit. What is the frequency of the source?

- A. 377 Hz
- B. 100 Hz
- C. 60 Hz
- D. 50 Hz

35. The capacitive reactance of a  $10\ \mu\text{F}$  capacitor at 1 kHz is approximately:

- A.  $15.9\ \Omega$
- B.  $159\ \Omega$

- C.  $1.59 \Omega$
- D.  $100 \Omega$

36. In a series circuit, the same quantity is common to all elements. That quantity is the:

- A. Voltage across each element
- B. Current through each element
- C. Power dissipated by each element
- D. Resistance of each element

37. The superposition theorem can be applied only to circuits that are:

- A. Purely resistive with no reactive elements
- B. Driven by a single independent source only
- C. Operating strictly at DC steady state
- D. Linear, so responses can be added independently

38. The total impedance of a series circuit with  $R = 50 \Omega$  and  $X_C = 50 \Omega$  has a magnitude of:

- A.  $70.7 \Omega$
- B.  $100 \Omega$
- C.  $0 \Omega$
- D.  $50 \Omega$

39. Thévenin's theorem reduces a linear two-terminal network to:

- A. A current source in parallel with a resistance
- B. Two independent sources connected in series

- C. A voltage source in series with an impedance
- D. A pure resistance with no source present

40. A 2 H inductor carries a current that changes at a rate of 3 A/s. What is the induced voltage?

- A. 1.5 V
- B. 6 V
- C. 0.67 V
- D. 2 V

41. In a purely capacitive AC circuit, the average real power consumed over a complete cycle is:

- A. Equal to the apparent power value
- B. Maximum at the resonant frequency
- C. Equal to  $V^2/X_C$  continuously
- D. Zero, since voltage and current are  $90^\circ$  apart

42. The quality factor (Q) of a resonant RLC circuit is a measure of its:

- A. Total power dissipated at resonance
- B. Phase shift at the half-power points
- C. Selectivity, or sharpness of the resonance peak
- D. DC resistance at zero frequency operation

43. A 12 V source charges an initially uncharged capacitor through a resistor. After one time constant, the capacitor voltage is approximately:

- A. 7.6 V
- B. 4.4 V

- C. 12 V
- D. 0 V

44. The Laplace transform of the function  $f(t) = t \cdot u(t)$  is:

- A.  $1/s$
- B.  $1/s^2$
- C.  $s$
- D.  $1/(s + 1)$

45. A system whose output at any time depends only on present and past inputs (never future inputs) is said to be:

- A. Linear
- B. Time-invariant
- C. Memoryless
- D. Causal

46. The final value theorem allows the steady-state value of  $f(t)$  to be found from  $F(s)$  by evaluating:

- A.  $\lim_{s \rightarrow 0} s \cdot F(s)$
- B.  $\lim_{s \rightarrow \infty} s \cdot F(s)$
- C.  $\lim_{s \rightarrow 0} F(s)/s$
- D.  $\lim_{s \rightarrow \infty} F(s)$

47. A signal  $x[n] = \{1, 2, 3\}$  is convolved with  $h[n] = \{1, 1\}$ . What is the length of the resulting output sequence?

- A. 2

- B. 3
- C. 4
- D. 6

48. The Bode magnitude plot shown represents a first-order system. What is its approximate corner (cutoff) frequency?

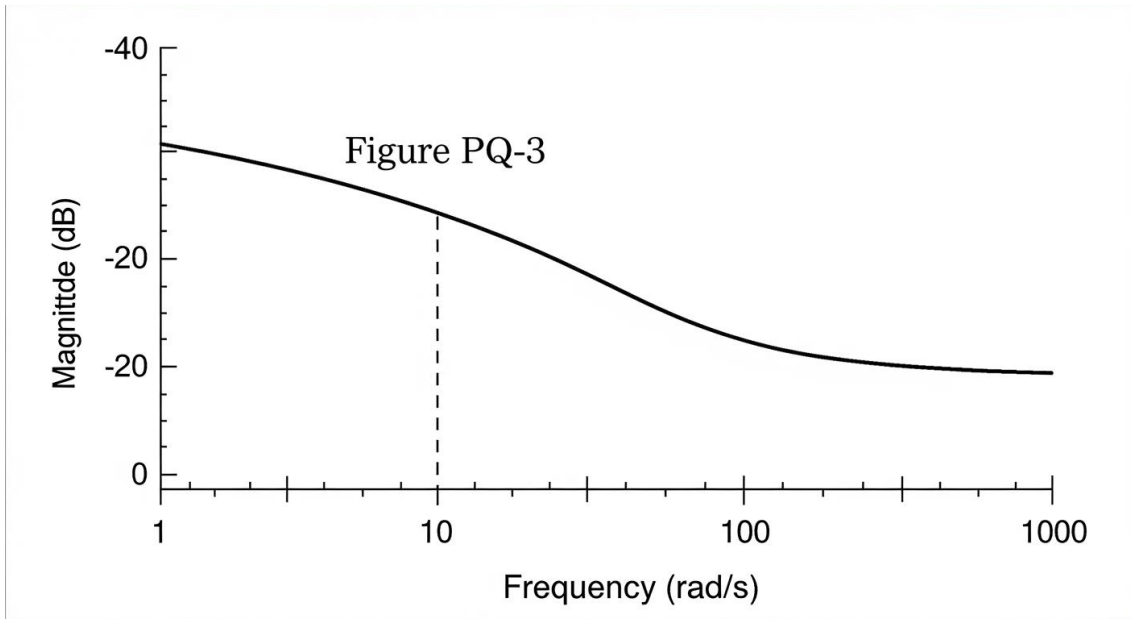

- A. 10 rad/s
- B. 100 rad/s
- C. 1000 rad/s
- D. 1 rad/s

49. A discrete-time system described by  $y[n] = 0.5 \cdot y[n-1] + x[n]$  is classified as:

- A. Recursive (infinite impulse response)
- B. Non-recursive (finite impulse response)
- C. Time-varying and unstable
- D. Purely combinational with no memory

50. The unit-step response of a system is the integral of its:

- A. Frequency response magnitude
- B. Transfer function poles
- C. Steady-state output value
- D. Impulse response

51. A 1 kHz sinusoid is sampled at 8 kHz. The normalized digital frequency (in radians per sample) of the sampled signal is:

- A.  $\pi/2$
- B.  $\pi$
- C.  $\pi/4$
- D.  $2\pi$

52. The transfer function of an ideal differentiator in the Laplace domain is:

- A.  $H(s) = s$
- B.  $H(s) = 1/s$
- C.  $H(s) = 1$
- D.  $H(s) = s^2$

53. Increasing the number of points  $N$  in a DFT of a fixed-duration signal primarily improves the:

- A. Time resolution of the transform output
- B. Signal-to-noise ratio of the input data
- C. Dynamic range of the quantized samples
- D. Frequency resolution of the spectrum

54. A linear-phase FIR filter has the desirable property of introducing:

- A. A frequency-dependent nonlinear group delay
- B. A constant group delay across all frequencies
- C. An unstable response for high filter orders
- D. Infinite memory of all past input samples

55. The z-transform of the unit step sequence  $u[n]$  is:

- A. 1
- B.  $z$
- C.  $z/(z - 1)$
- D.  $1/(z - 1)$

56. In an ideal op-amp with negative feedback, the voltage difference between the two input terminals is assumed to be:

- A. Equal to the output voltage divided by gain
- B. Set by the ratio of feedback resistors used
- C. Equal to the supply rail voltage difference
- D. Zero, the basis of the virtual-short concept

57. A voltage follower (unity-gain buffer) built from an op-amp is primarily used to provide:

- A. High voltage gain for weak input signals
- B. Impedance isolation between two circuit stages
- C. A 180-degree phase inversion of the input
- D. Frequency-selective filtering of the signal

58. The DC current gain ( $\beta$ ) of a bipolar junction transistor relates the:

- A. Collector current to the base current
- B. Emitter current to the collector current
- C. Base voltage to the emitter voltage
- D. Output power to the input power level

59. For the op-amp circuit shown, determine the output voltage  $V_{out}$ .

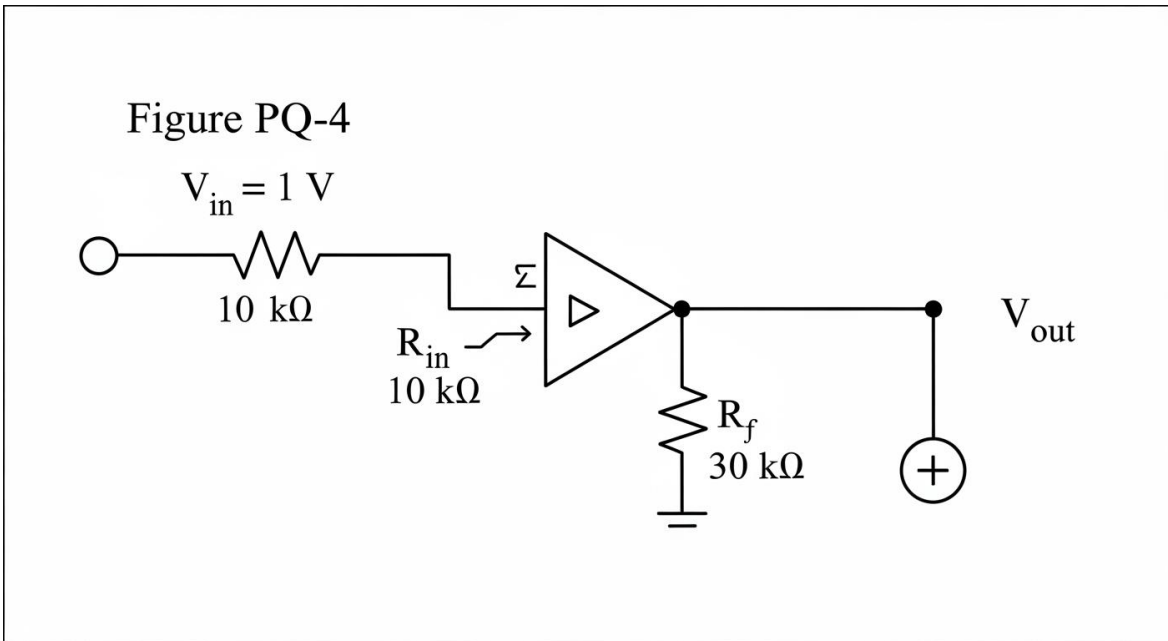

- A. +3 V
- B. +0.33 V
- C. -0.33 V
- D. -3 V

60. A light-emitting diode (LED) emits light when it is:

- A. Reverse biased beyond its breakdown voltage

- B. Operated at exactly zero bias voltage applied
- C. Forward biased so carriers recombine across the junction
- D. Subjected to a rapidly alternating high-frequency signal

61. In a CMOS logic inverter, static power dissipation in steady state is very low because:

- A. The output is permanently clamped to ground potential
- B. One of the two transistors is always switched off
- C. A large series resistor limits the supply current flow
- D. The input capacitance blocks all direct current flow

62. The bandwidth of an amplifier is the frequency range between the points where the gain falls to:

- A. 0.707 of its midband (maximum) voltage gain
- B. One-tenth of its midband voltage gain value
- C. Twice its midband maximum voltage gain value
- D. Zero, the complete cutoff of the signal output

63. A common-collector (emitter-follower) BJT amplifier is characterized by:

- A. High voltage gain with signal phase inversion
- B. High output impedance and low input impedance
- C. Voltage gain near unity and high current gain
- D. Strong attenuation of low-frequency signals only

64. A 240 V single-phase circuit delivers 4.8 kW to a resistive load. What is the load current?

- A. 5 A

- B. 11.5 A
- C. 50 A
- D. 20 A

65. The reactive power  $Q$  drawn by a purely inductive load is measured in:

- A. Volt-amperes reactive (VAR)
- B. Watts (W)
- C. Volt-amperes (VA)
- D. Joules per second (J/s)

66. A 60 Hz, 4-pole synchronous generator must rotate at what mechanical speed to produce its rated frequency?

- A. 3600 rpm
- B. 900 rpm
- C. 1800 rpm
- D. 1200 rpm

67. In a balanced three-phase delta-connected load, the relationship between line current and phase current is:

- A. Line current equals the phase current exactly
- B. Line current equals  $\sqrt{3}$  times the phase current
- C. Line current equals one-third the phase current
- D. Line current equals  $\sqrt{2}$  times the phase current

68. A transformer rated 25 kVA, 480/120 V has a full-load secondary current of approximately:

- A. 52 A
- B. 25 A
- C. 120 A
- D. 208 A

69. The slip of a three-phase induction motor at the instant of starting (rotor stationary) is:

- A. 1.0 (or 100%)
- B. 0.0 (or 0%)
- C. 0.5 (or 50%)
- D. Negative, indicating generation

70. A DC shunt motor's speed is most directly controlled by varying the:

- A. Number of armature commutator segments
- B. Field flux or the armature applied voltage
- C. Physical air-gap length within the motor
- D. Mechanical load torque on the output shaft

71. Three identical impedances each of  $(3 + j4) \Omega$  are connected in a balanced wye. What is the magnitude of each phase impedance?

- A.  $3 \Omega$
- B.  $4 \Omega$
- C.  $5 \Omega$
- D.  $7 \Omega$

72. The purpose of grounding the neutral point of a power distribution system is primarily to:

- A. Provide a safe reference and fault-current return path
- B. Increase the delivered real power to the loads
- C. Raise the system operating voltage uniformly
- D. Eliminate all reactive power in the network

73. Gauss's law relates the electric flux through a closed surface to the:

- A. Magnetic field circulating around the surface boundary
- B. Rate of change of magnetic flux through the surface
- C. Total current passing through the enclosed volume
- D. Net electric charge enclosed within the surface

74. Faraday's law of electromagnetic induction states that the induced EMF in a loop is proportional to the:

- A. Magnitude of the steady magnetic flux through it
- B. Total resistance of the conducting loop material
- C. Rate of change of magnetic flux through the loop
- D. Square of the current flowing in the loop wire

75. The skin effect in a conductor carrying high-frequency AC current causes the current to:

- A. Distribute uniformly across the entire cross-section
- B. Concentrate near the outer surface of the conductor
- C. Flow only through the geometric center of the wire
- D. Cease entirely above a certain critical frequency

76. The characteristic impedance of a lossless transmission line depends on its:

- A. Distributed inductance and capacitance per unit length
- B. Total physical length and the source frequency
- C. Connected load impedance value at the far end
- D. Magnitude of the applied input signal voltage

77. A control system in which the output has no effect on the control action is called:

- A. A closed-loop feedback system
- B. A proportional-integral system
- C. A critically damped system
- D. An open-loop system

78. The transfer function of a pure integrator is:

- A.  $H(s) = s$
- B.  $H(s) = 1/s$
- C.  $H(s) = K$  (constant)
- D.  $H(s) = s + 1$

79. For a second-order underdamped system, decreasing the damping ratio  $\zeta$  toward zero causes the percent overshoot to:

- A. Decrease toward zero overshoot
- B. Remain constant regardless of  $\zeta$
- C. Increase toward larger overshoot
- D. Become negative (undershoot)

80. The number of encirclements of the  $-1$  point in a Nyquist plot is used to assess a system's:

- A. Closed-loop stability
- B. Steady-state tracking error
- C. Bandwidth in hertz
- D. Resonant peak gain

81. A lead compensator is typically added to a control loop to improve the system's:

- A. Steady-state error to a ramp input
- B. DC gain at very low frequencies
- C. Resistance to high-frequency noise
- D. Transient response and phase margin

82. For a unity-feedback system with open-loop gain  $G(s) = K/[s(s + 2)]$ , increasing the gain  $K$  generally:

- A. Increases the damping ratio of the response
- B. Increases overshoot and reduces stability margin
- C. Has no effect on the transient response shape
- D. Eliminates the steady-state error to a ramp

83. The steady-state error of a Type 1 system to a unit ramp input is:

- A. A finite nonzero constant set by the velocity error constant
- B. Always exactly zero regardless of the loop gain value
- C. Infinite, growing without bound over time forever
- D. Equal to one-half of the applied input amplitude always

84. The process of converting a continuous-amplitude signal into a finite set of discrete amplitude levels is called:

- A. Sampling
- B. Encoding
- C. Quantization
- D. Modulation

85. Pulse-code modulation (PCM) represents an analog signal by:

- A. Varying the carrier amplitude continuously
- B. Shifting the carrier phase proportionally
- C. Adjusting the carrier frequency smoothly
- D. Encoding sampled amplitudes as binary words

86. In digital communication, intersymbol interference (ISI) is primarily caused by:

- A. Random thermal noise added in the receiver
- B. Channel bandwidth limitations spreading pulses
- C. Carrier frequency offset at the transmitter
- D. Quantization rounding of the sampled values

87. The bandwidth efficiency of a digital modulation scheme is expressed in units of:

- A. Hertz per watt
- B. Watts per hertz
- C. Bits per second per hertz
- D. Symbols per watt-second

88. Time-division multiplexing (TDM) allows multiple signals to share a channel by:

- A. Assigning each signal a distinct time slot in rotation
- B. Assigning each signal a distinct frequency band
- C. Assigning each signal a unique spreading code
- D. Transmitting all signals on the same time and frequency

89. In the TCP/IP model, which protocol is responsible for reliable, connection-oriented data transfer between hosts?

- A. UDP
- B. TCP
- C. IP
- D. ARP

90. A MAC (media access control) address identifies a device at which layer?

- A. Application layer
- B. Transport layer
- C. Network layer
- D. Data link layer

91. How many usable host addresses are available in an IPv4 subnet with a /29 prefix?

- A. 6
- B. 8
- C. 14
- D. 2

92. The Domain Name System (DNS) primarily provides which service on a network?

- A. Encrypting data packets in transit between hosts
- B. Assigning dynamic IP addresses to new devices
- C. Translating human-readable names into IP addresses
- D. Routing packets between separate autonomous systems

93. Convert the decimal number 26 to binary.

- A. 10101
- B. 11010
- C. 11100
- D. 10110

94. According to De Morgan's theorem, the expression  $(A \cdot B)'$  is equivalent to:

- A.  $A' \cdot B'$
- B.  $A \cdot B$
- C.  $A + B$
- D.  $A' + B'$

95. For the logic circuit shown, what is the output F when both inputs A and B are at logic 1?

Figure PQ-5

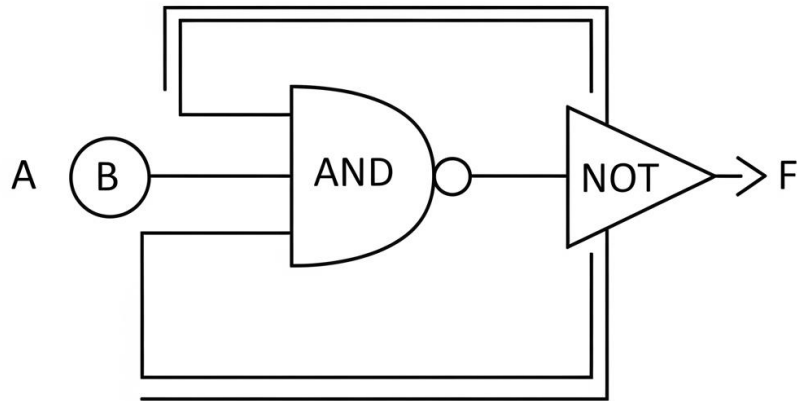

- A. 0
- B. 1
- C. Undefined
- D. High impedance

96. A D flip-flop transfers the value at its D input to the output Q:

- A. Continuously, whenever the D input changes
- B. Only when the asynchronous reset is asserted
- C. On the active edge of the clock signal
- D. After a fixed delay independent of the clock

97. How many address lines are required to uniquely address 1,024 memory locations?

- A. 8
- B. 16
- C. 32
- D. 10

98. The output of an XOR gate is logic HIGH when:

- A. Both inputs are at logic HIGH level
- B. The two inputs are at different logic levels
- C. Both inputs are at logic LOW level
- D. At least one input is at logic HIGH level

99. A 3-bit binary up-counter reaches its maximum count value of:

- A. 3
- B. 4
- C. 7
- D. 8

100. In a synchronous sequential circuit, all flip-flops change state:

- A. At random times determined by input delays
- B. One after another in a ripple sequence
- C. Simultaneously on a common clock edge
- D. Only when the master reset is released

101. The decimal value 200 expressed in hexadecimal is:

- A. 0xCA
- B. 0xB8
- C. 0xD0
- D. 0xC8

102. In a computer system, the component that performs arithmetic and logic operations is the:

- A. Control unit
- B. Arithmetic logic unit (ALU)
- C. Memory address register
- D. Program counter

103. The principle of locality of reference, which makes caching effective, states that programs tend to:

- A. Access memory locations near recently accessed ones
- B. Distribute memory accesses uniformly across all addresses
- C. Access each memory location exactly once per run
- D. Avoid reusing any previously accessed data values

104. In a five-stage instruction pipeline, the theoretical maximum speedup over a non-pipelined design is approximately:

- A. 2 times
- B. 1 time (no speedup)
- C. 5 times
- D. 25 times

105. An interrupt in a computer system is best described as a mechanism that:

- A. Permanently halts all processor execution immediately
- B. Signals the processor to suspend current work and respond to an event
- C. Increases the processor clock frequency temporarily
- D. Erases the contents of main memory during a fault

106. Virtual memory allows a computer to:

- A. Increase the physical clock speed of the processor
- B. Run programs entirely from the cache without main memory
- C. Store data permanently after the power is removed
- D. Execute programs larger than the available physical RAM

107. In Big-O notation, the worst-case time complexity of linear search through an unsorted array of  $n$  elements is:

- A.  $O(n)$
- B.  $O(\log n)$
- C.  $O(1)$
- D.  $O(n^2)$

108. A recursive function must always include which feature to avoid infinite recursion?

- A. A global variable shared across all calls
- B. A loop construct inside the function body
- C. A base case that terminates the recursion
- D. A pointer to the previous stack frame used

109. In software engineering, a "unit test" is designed to verify the correctness of:

- A. The entire integrated system end to end
- B. The user interface appearance and layout
- C. The network communication between servers
- D. An individual component or function in isolation

110. A compiler differs from an interpreter in that a compiler:

- A. Executes the source code one line at a time directly
- B. Translates the entire source program into machine code before execution
- C. Requires the source code to be present at every runtime
- D. Cannot detect any syntax errors before the program runs

## Answer Key and Full Answer Explanations

**1. B** — The derivative of  $\cos(x)$  is  $-\sin(x)$ , a fundamental result from differentiating the cosine function. The negative sign reflects that cosine is decreasing where sine is positive.

**2. D** —  $\int 2x \, dx = x^2 + C$  by the power rule, raising the exponent and dividing by the new power. The constant of integration  $C$  is required for any indefinite integral.

**3. A** — Multiplying by  $180/\pi$  converts radians to degrees:  $(2\pi/3)(180/\pi) = 120^\circ$ . The  $\pi$  values cancel, leaving a clean degree measure.

**4. C** — For perpendicular vectors the resultant magnitude is  $\sqrt{(6^2 + 8^2)} = \sqrt{100} = 10$ , the Pythagorean combination. This is the standard 6-8-10 right-triangle scaling of the 3-4-5 ratio.

**5. B** — By the Pythagorean theorem,  $c = \sqrt{(5^2 + 12^2)} = \sqrt{169} = 13$ . The 5-12-13 set is a common right-triangle triple worth memorizing for the exam.

**6. A** — Factoring gives  $(x^2 - 4)/(x - 2) = (x + 2)$ , so the limit as  $x \rightarrow 2$  is  $2 + 2 = 4$ . The removable discontinuity cancels, leaving a finite value.

**7. D** — The Maclaurin series for  $e^x$  is  $1 + x + x^2/2! + x^3/3! + \dots$ , with all positive terms. Every derivative of  $e^x$  equals  $e^x$ , which equals 1 at  $x = 0$ .

**8. C** — The period of  $\sin(bx)$  is  $2\pi/b$ , so for  $\sin(2x)$  it is  $2\pi/2 = \pi$ . Doubling the angular coefficient halves the period.

**9. A** — The inverse of a diagonal matrix is found by reciprocating each diagonal entry:  $1/2 = 0.5$  and  $1/4 = 0.25$ . Off-diagonal zeros remain zero.

**10. B** — Integrating  $dy/dx = x$  gives  $y = x^2/2 + C$ ; applying  $y(0) = 1$  sets  $C = 1$ . The initial condition fixes the unique particular solution.

**11. D** — Treating  $y$  as constant,  $\partial/\partial x$  of  $3x^2y$  is  $6xy$ , and the  $y^3$  term vanishes because it has no  $x$ . Partial differentiation holds all other variables fixed.

- 12. A** — The gradient is the vector of partial derivatives,  $(\partial f/\partial x, \partial f/\partial y) = (2x, 2y)$ . It points in the direction of steepest increase of the scalar field.
- 13. C** — A deck has 13 hearts out of 52 cards, giving  $13/52 = 1/4$ . Each of the four suits is equally likely.
- 14. B** — The complement rule gives  $P(\text{not } A) = 1 - P(A) = 1 - 0.3 = 0.7$ . Probabilities of an event and its complement sum to one.
- 15. D** — There are 6 ways to roll a sum of 7 out of 36 equally likely outcomes, so  $6/36 = 1/6$ . Seven is the most probable sum on two dice.
- 16. B** — With the data sorted as 4, 8, 8, 10, 20, the median is the middle (third) value, which is 8. The median is unaffected by the extreme value 20.
- 17. B** — The word MATH has four distinct letters, giving  $4! = 24$  permutations. Each arrangement is unique because no letters repeat.
- 18. C** — The first fundamental canon of the NSPE Code requires engineers to hold paramount the safety, health, and welfare of the public. This duty overrides employer profit or personal advancement.
- 19. A** — Certifying a design believed to be unsafe violates the duty to protect the public, so the engineer must refuse regardless of the fee or liability waivers. Client acceptance of liability does not relieve the engineer's ethical obligation.
- 20. D** — Accepting valuable gifts intended to influence engineering judgment is a conflict of interest prohibited by the NSPE Code. Disclosure or employer notification does not cure the impropriety of the inducement.
- 21. A** — The NSPE Code requires engineers to perform services only in areas of their competence, associating with qualified experts when work falls outside that scope. This protects the public from unqualified judgments.
- 22. A** — The effective monthly rate equals the nominal annual rate divided by the number of periods:  $12\%/12 = 1\%$  per month. Compounding frequency determines the periodic rate.
- 23. D** — The present worth of the future receipt is  $26,620 \times 0.7513 \approx \$20,000$ , which exactly offsets the \$20,000 cost, giving a net present worth of zero. A zero NPW means the project earns precisely the 10% rate.
- 24. C** — Capitalized cost of a perpetual uniform expense equals  $A/i = 1,000/0.05 = \$20,000$ . This is the principal whose interest alone funds the recurring cost forever.
- 25. B** — The coupon rate is the annual coupon divided by face value:  $60/1,000 = 6\%$ . This is the bond's stated nominal interest rate.

- 26. D** — A public project is economically justified when its benefit-cost ratio is at least 1, meaning benefits equal or exceed costs. A ratio below one indicates the costs outweigh the benefits.
- 27. C** — Resistivity is the intrinsic material property quantifying opposition to current per unit length and cross-sectional area. Resistance then scales with geometry as  $R = \rho L/A$ .
- 28. A** — Insulators have a large energy band gap that keeps electrons from reaching the conduction band at normal temperatures. This prevents the free-carrier flow that defines conductors.
- 29. C** — The piezoelectric effect produces a voltage in certain crystals when mechanical stress deforms them. This underlies sensors, transducers, and precision oscillators.
- 30. B** — A thermistor is a temperature-sensitive resistor whose resistance changes significantly and predictably with temperature. This makes it useful for temperature measurement and compensation.
- 31. A** — Series resistances add to  $36 \Omega$ , so  $I = V/R = 24/36 = 0.667 \text{ A}$ . The same current flows through all series elements.
- 32. D** — Parallel resistors combine as  $(3 \times 6)/(3 + 6) = 18/9 = 2 \Omega$ . The equivalent is always less than the smallest branch resistance.
- 33. B** — The  $6 \Omega$  and  $12 \Omega$  parallel combination is  $(6 \times 12)/18 = 4 \Omega$ , which adds in series with the  $4 \Omega$  resistor to give  $8 \Omega$  total. Parallel branches reduce first, then series elements sum.
- 34. C** — Frequency  $f = \omega/2\pi = 377/(2\pi) \approx 60 \text{ Hz}$ , the standard North American line frequency. The  $377 \text{ rad/s}$  angular frequency is the recognizable signature of  $60 \text{ Hz}$ .
- 35. A** — Capacitive reactance  $X_C = 1/(2\pi fC) = 1/(2\pi \cdot 1000 \cdot 10 \times 10^{-6}) \approx 15.9 \Omega$ . Reactance falls as frequency or capacitance rises.
- 36. B** — In a series circuit the current is the same through every element because there is only one path for charge to flow. Voltage instead divides among the elements.
- 37. D** — Superposition applies only to linear circuits, where the response to multiple sources equals the sum of responses to each source acting alone. Nonlinear elements invalidate this additivity.
- 38. A** — Series impedance magnitude is  $\sqrt{R^2 + X_C^2} = \sqrt{50^2 + 50^2} \approx 70.7 \Omega$ . The reactive and resistive parts combine as perpendicular components.
- 39. C** — Thévenin's theorem models a linear two-terminal network as a single voltage source in series with an equivalent impedance. This simplifies load analysis at the terminals.
- 40. B** — Inductor voltage is  $v = L(di/dt) = 2 \times 3 = 6 \text{ V}$ . The induced voltage opposes the change in current per Lenz's law.

- 41. D** — In a purely capacitive circuit, voltage and current are  $90^\circ$  out of phase, so the average real power over a cycle is zero. Only reactive power is exchanged, with no net energy dissipated.
- 42. C** — The quality factor  $Q$  measures the selectivity or sharpness of a resonant circuit's response peak. A higher  $Q$  yields a narrower bandwidth around the resonant frequency.
- 43. A** — After one time constant a charging capacitor reaches  $1 - e^{-1} \approx 63.2\%$  of the source:  $12 \times 0.632 \approx 7.6$  V. The exponential approach to the final value defines RC charging.
- 44. B** — The Laplace transform of  $t \cdot u(t)$  is  $1/s^2$ , obtained from the ramp transform pair. Each additional power of  $t$  adds a factor of  $1/s$ .
- 45. D** — A causal system produces output that depends only on present and past inputs, never future ones. Causality is required for any real-time physically realizable system.
- 46. A** — The final value theorem evaluates the steady-state value as  $\lim(s \rightarrow 0) s \cdot F(s)$ , provided the system is stable. It avoids inverse-transforming back to the time domain.
- 47. C** — Linear convolution of sequences of lengths 3 and 2 yields an output of length  $3 + 2 - 1 = 4$ . The output length is one less than the sum of the input lengths.
- 48. B** — The flat 0 dB response breaks downward at 100 rad/s with a  $-20$  dB/decade slope, marking the first-order corner frequency at 100 rad/s. The corner is where the asymptotes intersect.
- 49. A** — The feedback term  $0.5 \cdot y[n-1]$  makes the system recursive with an infinite impulse response. Dependence on past outputs distinguishes IIR from FIR systems.
- 50. D** — The step response is the running integral of the impulse response, since the unit step is the integral of the unit impulse. Linearity lets the same operation carry to the system output.
- 51. C** — Normalized digital frequency is  $\omega = 2\pi f/f_s = 2\pi(1000)/8000 = \pi/4$  rad/sample. It expresses analog frequency relative to the sampling rate.
- 52. A** — An ideal differentiator has transfer function  $H(s) = s$ , since differentiation in time corresponds to multiplication by  $s$ . Its gain rises with frequency.
- 53. D** — Increasing the DFT length  $N$  over a fixed signal duration narrows the spacing between frequency bins, improving frequency resolution. More samples refine the spectral detail.
- 54. B** — A linear-phase FIR filter delays all frequency components equally, producing a constant group delay. This preserves waveform shape without phase distortion.
- 55. C** — The  $z$ -transform of  $u[n]$  is  $z/(z - 1)$  for  $|z| > 1$ , summing the geometric series of the step. The pole at  $z = 1$  reflects the step's persistent value.

- 56. D** — With negative feedback, the op-amp drives its two inputs to nearly equal potential, so their difference is approximately zero — the virtual-short principle. This assumption underlies standard op-amp circuit analysis.
- 57. B** — A voltage follower has unity gain and very high input with very low output impedance, isolating one stage from loading the next. It buffers signals without changing their amplitude.
- 58. A** — The BJT DC current gain  $\beta$  is the ratio of collector current to base current,  $\beta = I_C/I_B$ . A small base current controls a much larger collector current.
- 59. D** — For the inverting amplifier,  $V_{out} = -(R_f/R_{in}) \cdot V_{in} = -(30k/10k)(1) = -3$  V. The negative sign reflects the  $180^\circ$  inversion of the inverting configuration.
- 60. C** — An LED emits light under forward bias as electrons and holes recombine across the junction, releasing photons. Reverse bias or zero bias produces no light output.
- 61. B** — In a static CMOS inverter, either the pull-up or pull-down transistor is always off, so no direct path exists from supply to ground. This eliminates static current and keeps standby power very low.
- 62. A** — Amplifier bandwidth spans the two frequencies where voltage gain drops to 0.707 (the  $-3$  dB points) of the midband value. These half-power frequencies bound the passband.
- 63. C** — The common-collector (emitter-follower) stage has a voltage gain near unity but high current gain, with no phase inversion. Its high input and low output impedance make it a good buffer.
- 64. D** — Load current is  $I = P/V = 4,800/240 = 20$  A for a resistive single-phase load. Power factor is unity, so real power equals apparent power.
- 65. A** — Reactive power is measured in volt-amperes reactive (VAR), distinguishing it from real power in watts. It represents energy exchanged but not dissipated by reactive elements.
- 66. C** — Synchronous speed  $n = 120f/P = 120(60)/4 = 1,800$  rpm. The machine must turn at this speed to generate the rated 60 Hz output.
- 67. B** — In a balanced delta load, the line current is  $\sqrt{3}$  times the phase current, while line and phase voltages are equal. The  $\sqrt{3}$  factor arises from the phasor sum at the connection nodes.
- 68. D** — Secondary full-load current is  $I = S/V = 25,000/120 \approx 208$  A. The lower-voltage winding carries the higher current for a given kVA rating.
- 69. A** — At standstill the rotor speed is zero, so slip  $s = (n_s - n)/n_s = 1$ , or 100%. Slip falls toward a small value as the motor accelerates under load.
- 70. B** — A DC shunt motor's speed is controlled primarily by adjusting the field flux or the armature voltage, since speed is proportional to back-EMF over flux. These are the two principal control variables.

- 71. C** — The magnitude of each phase impedance is  $|3 + j4| = \sqrt{3^2 + 4^2} = 5 \Omega$ . The connection type does not change the per-phase impedance magnitude.
- 72. A** — Grounding the system neutral establishes a safe voltage reference and provides a low-impedance return path for fault current. This enables protective devices to clear faults quickly.
- 73. D** — Gauss's law states that the net electric flux through a closed surface is proportional to the total charge enclosed. It links field behavior directly to the source charge.
- 74. C** — Faraday's law gives the induced EMF as proportional to the rate of change of magnetic flux through the loop. A static flux induces no EMF; only changing flux does.
- 75. B** — The skin effect forces high-frequency AC toward the conductor's outer surface, reducing the effective cross-section and raising AC resistance. This worsens with increasing frequency.
- 76. A** — The characteristic impedance of a lossless line is  $Z_0 = \sqrt{L/C}$ , depending only on its distributed inductance and capacitance per unit length. It is independent of line length and frequency.
- 77. D** — In an open-loop system the output is not fed back to influence the control action. Without feedback, the system cannot self-correct for disturbances or errors.
- 78. B** — A pure integrator has transfer function  $H(s) = 1/s$ , since integration in time corresponds to division by  $s$ . Its gain falls with increasing frequency.
- 79. C** — Lowering the damping ratio  $\zeta$  toward zero increases the percent overshoot of a second-order step response. Less damping allows larger oscillatory excursions before settling.
- 80. A** — The Nyquist criterion uses encirclements of the  $-1$  point to determine closed-loop stability from the open-loop response. The encirclement count relates to right-half-plane poles.
- 81. D** — A lead compensator adds phase near the crossover frequency, improving phase margin and speeding the transient response. It primarily enhances stability and response time rather than steady-state accuracy.
- 82. B** — Raising  $K$  in  $K/[s(s+2)]$  pushes the closed-loop poles toward lower damping, increasing overshoot and shrinking the stability margin. Higher gain trades stability for speed.
- 83. A** — A Type 1 system tracks a ramp with a finite nonzero steady-state error set by the velocity error constant  $K_v$ . It eliminates step error but cannot fully follow a ramp.
- 84. C** — Quantization maps a continuous range of amplitudes onto a finite set of discrete levels. It is the step that introduces quantization error in digital conversion.
- 85. D** — PCM samples the analog signal and encodes each sampled amplitude as a binary code word. Quantization plus binary encoding produces the digital bit stream.

- 86. B** — Intersymbol interference arises when limited channel bandwidth spreads pulses so they overlap neighboring symbols. Proper pulse shaping and equalization mitigate it.
- 87. C** — Bandwidth efficiency is expressed in bits per second per hertz, relating data rate to occupied bandwidth. Higher-order modulation increases this efficiency.
- 88. A** — Time-division multiplexing interleaves signals by giving each a dedicated time slot in a repeating frame. All channels share the full bandwidth but at different times.
- 89. B** — TCP provides reliable, connection-oriented delivery with acknowledgments, sequencing, and retransmission. It guarantees ordered, error-checked data between hosts.
- 90. D** — A MAC address operates at the data link layer (Layer 2) to identify devices on a local network segment. It enables frame delivery within the same subnet.
- 91. A** — A /29 subnet has  $2^3 = 8$  total addresses, and subtracting the network and broadcast addresses leaves 6 usable hosts. The host portion spans the remaining three bits.
- 92. C** — DNS translates human-readable domain names into the numerical IP addresses routers use. It functions as the naming directory of the internet.
- 93. B** — Decimal  $26 = 16 + 8 + 2$ , which is 11010 in binary. Summing the corresponding powers of two confirms the conversion.
- 94. D** — By De Morgan's theorem,  $(A \cdot B)' = A' + B'$ , turning a negated AND into an OR of complements. The operation flips both the variables and the connective.
- 95. A** — The AND gate outputs 1 for inputs  $A = B = 1$ , and the following NOT gate inverts it to 0, so  $F = 0$ . This two-gate chain forms a NAND function.
- 96. C** — A D flip-flop captures the D input and presents it at Q only on the active clock edge. Edge triggering distinguishes it from a level-sensitive latch.
- 97. D** — Addressing 1,024 locations requires  $\log_2(1024) = 10$  address lines, since  $2^{10} = 1,024$ . Each address line doubles the addressable space.
- 98. B** — An XOR gate outputs HIGH only when its two inputs differ. Equal inputs, whether both high or both low, produce a LOW output.
- 99. C** — A 3-bit counter counts from 0 to  $2^3 - 1 = 7$  before rolling over. The maximum value is one less than the modulus.
- 100. C** — In a synchronous circuit, all flip-flops are driven by a common clock and change state together on the same edge. This eliminates the cumulative delay of ripple counters.

**101. D** — Decimal  $200 = 12 \times 16 + 8 = C8$  in hexadecimal, written  $0xC8$ . The high nibble C represents 12 and the low nibble 8 represents the remainder.

**102. B** — The arithmetic logic unit performs the arithmetic and logic operations within the processor. The control unit instead directs and sequences operations.

**103. A** — Locality of reference means programs tend to access memory near recently used locations, both spatially and temporally. This predictable clustering is what makes caching effective.

**104. C** — An ideal N-stage pipeline yields a maximum speedup of N, so a five-stage pipeline approaches  $5\times$ . Hazards and stalls reduce this in practice.

**105. B** — An interrupt signals the processor to pause its current task, service the event, then resume where it left off. This allows responsive, event-driven handling without constant polling.

**106. D** — Virtual memory uses disk storage as an extension of RAM, letting programs exceed the physical memory available. Pages move between disk and RAM on demand.

**107. A** — Linear search may inspect every element, giving worst-case time complexity  $O(n)$  for an unsorted array. The target could be last or absent entirely.

**108. C** — A recursive function needs a base case that stops further recursive calls, preventing infinite recursion and stack overflow. The recursive case must progress toward this base condition.

**109. D** — A unit test verifies a single component or function in isolation from the rest of the system. This pinpoints defects at the smallest testable level.

**110. B** — A compiler translates the entire source program into machine code before execution, unlike an interpreter that executes line by line. The resulting executable then runs without the source present.