

PRACTICE EXAM 21: LIVING ENVIRONMENT REGENTS SIMULATION

Time Allowed: 3 hours | Total Points: 85 | Passing: 65 scaled | Mastery: 85 scaled

PART A — CORE CONTENT MULTIPLE CHOICE (30 Questions, 30 Points)

Answer all questions in this part.

1. Which of the following best describes the role of organic molecules called proteins in living organisms?

- A. Proteins store all of the cell's genetic instructions
- B. Proteins primarily serve as a long-term energy source
- C. Proteins build structures and catalyze chemical reactions
- D. Proteins make up the rigid wall of every plant cell

2. Which type of organic molecule serves as the primary short-term energy source for most living cells?

- A. carbohydrates, which are broken down to release energy
- B. nucleic acids, which carry the genetic information
- C. lipids, which make up the cell membrane structure
- D. proteins, which catalyze the biochemical reactions

3. The cell membrane is composed primarily of a double layer of
- A. carbohydrates with embedded protein chains
 - B. phospholipids with embedded protein molecules
 - C. nucleic acids attached to ribosome subunits
 - D. cellulose fibers cross-linked at right angles
4. When a plant cell is placed in a hypotonic solution, water moves into the cell, and the cell becomes
- A. shriveled because water moves out of the cell
 - B. unchanged because water cannot cross the cell wall
 - C. lysed because the cell wall ruptures rapidly
 - D. turgid because water enters and presses outward
5. The mitochondria of muscle cells are especially abundant because muscle cells require
- A. large amounts of ATP for muscle contraction
 - B. extensive storage of genetic material for division
 - C. extra protein production for tissue building
 - D. immediate breakdown of dietary fats for storage
6. A substance that binds to an enzyme and slows or prevents the enzyme from working is called

- A. a substrate that is broken down by the enzyme
- B. an inhibitor that interferes with enzyme activity
- C. a product released by the chemical reaction
- D. a coenzyme that activates the enzyme's function

7. The Calvin cycle (light-independent reactions) of photosynthesis takes place in the

- A. nucleus of the plant cell
- B. thylakoid membranes of the chloroplast
- C. mitochondria of the plant cell
- D. stroma of the chloroplast

8. The first stage of cellular respiration, in which glucose is broken down into two pyruvate molecules, is called

- A. the Krebs cycle inside the mitochondria
- B. glycolysis in the cytoplasm of the cell
- C. the electron transport chain in the membrane
- D. fermentation in the absence of oxygen gas

9. In the absence of oxygen, some yeast cells produce ATP through a process that also produces

- A. ethanol and carbon dioxide as waste products
- B. only water as a single final waste product

- C. glucose to be stored for later use by the cell
- D. only oxygen released into the surroundings

10. Which of the following nitrogen bases is found only in RNA and not in DNA?

- A. the nitrogen base adenine
- B. the nitrogen base guanine
- C. the nitrogen base cytosine
- D. the nitrogen base uracil

11. The genetic code is described as "redundant" because

- A. each amino acid is coded by only a single codon
- B. each gene codes for many different proteins together
- C. many amino acids are coded by more than one codon
- D. each protein is built from only one type of amino acid

12. The fact that nearly all organisms use the same triplet code to specify amino acids supports the conclusion that

- A. all species are unrelated and evolved independently
- B. all life on Earth descended from a common ancestor
- C. mutations rarely occur in any species across time
- D. all species have the same number of genes in their cells

13. According to Mendel's law of segregation, during gamete formation each gamete receives

- A. both alleles for each gene from the parent
- B. only the dominant allele for each gene from the parent
- C. only the recessive allele for each gene from the parent
- D. only one allele for each gene from the parent

14. A test cross is used to determine whether an organism showing a dominant phenotype is

- A. homozygous dominant or heterozygous for the trait
- B. heterozygous or homozygous recessive for the trait
- C. carrying two different recessive alleles for the trait
- D. capable of producing only dominant offspring always

15. A genetic disorder caused by an extra copy of chromosome 21 in a person's cells is

- A. cystic fibrosis caused by an autosomal recessive allele
- B. hemophilia caused by an X-linked recessive allele
- C. Down syndrome caused by trisomy of chromosome 21
- D. sickle cell anemia caused by a single point mutation

16. When two heterozygous parents ($Tt \times Tt$) have offspring, the phenotype ratio of dominant to recessive in their children is expected to be

- A. 1 dominant to 1 recessive in the offspring
- B. 3 dominant to 1 recessive in the offspring
- C. 1 dominant to 3 recessive in the offspring
- D. 9 dominant to 7 recessive in the offspring

17. A modern explanation for why a giraffe has a long neck is that

- A. ancestors with longer necks survived and reproduced more
- B. each individual giraffe stretches its neck during its lifetime
- C. giraffes purposefully chose to develop longer necks over time
- D. environmental conditions caused all giraffe necks to grow

18. Which of the following provides the strongest molecular evidence that two species share a recent common ancestor?

- A. they live in the same geographic area together
- B. they appear similar in their adult body structures
- C. they belong to the same ecological community
- D. they share very similar sequences of nucleotides in their DNA

19. In a small isolated population of plants, a random change in the frequency of a recessive allele occurs without any obvious cause. This change is best described as

- A. natural selection by environmental pressure

- B. coevolution between two interacting species
- C. genetic drift in a small isolated population
- D. artificial selection by a human breeder over time

20. The Arctic fox has white fur in winter and brown fur in summer. This coloration is best described as

- A. an adaptation that improves the fox's camouflage seasonally
- B. a behavior the fox chooses to display each season
- C. evidence that the fox is unrelated to other fox species
- D. a sign that the fox's environment is unchanging year-round

21. A group of organisms of the same species living in the same area at the same time is called a

- A. community of many different species
- B. population of individuals of one species
- C. ecosystem of organisms and the environment
- D. biosphere of all life on Earth at once

22. The physical place where an organism lives, such as a particular tree or pond, is best described as the organism's

- A. niche, including its full ecological role
- B. ecosystem, including all interacting parts
- C. trophic level, indicating its food role

D. habitat, the specific location it occupies

23. Barnacles attach to the skin of whales and gain transportation through the ocean without harming the whale. This relationship is best described as

A. mutualism, with benefit to both species

B. parasitism, with harm to the whale by barnacles

C. commensalism, with benefit only to the barnacle

D. predation, with the whale as the prey

24. If a producer in an ecosystem contains 10,000 kilocalories of energy, the approximate amount of energy that primary consumers will obtain from feeding on that producer is

A. 1,000 kilocalories transferred to the consumers

B. 5,000 kilocalories transferred to the consumers

C. 9,000 kilocalories transferred to the consumers

D. 10,000 kilocalories transferred to the consumers

25. In an aquatic ecosystem, the growth of producers is most often limited by the availability of

A. predators that eat the producers

B. light penetrating the water column

C. food for the producers to consume

D. heat from underwater volcanic vents

26. Over hundreds of years, a small pond gradually fills in with sediment and plant material and is eventually replaced by a meadow and then a forest. This series of community changes is called

- A. acid rain damaging the original ecosystem
- B. urbanization altering the landscape over time
- C. ecological succession changing the community
- D. deforestation eliminating the original forest

27. Fertilizer runoff from a farm enters a nearby lake, leading to a massive bloom of algae. When the algae die and decompose, oxygen levels in the water drop sharply and fish begin to die. This process is best described as

- A. acid rain damaging the aquatic species
- B. urbanization of the surrounding land
- C. desertification of the lake's basin
- D. eutrophication of the lake ecosystem

28. The maximum population of a species that a given environment can support over a long period of time is called

- A. the carrying capacity of the environment
- B. the biotic potential of the species
- C. the ecological niche of the species
- D. the natality rate of the population

29. When body temperature rises during exercise, sweat glands release moisture that evaporates from the skin. The effect of evaporation on the body is to

- A. raise body temperature further by adding heat
- B. produce more sweat over a longer period of time
- C. lower body temperature by removing heat
- D. increase blood pressure to compensate for heat

30. The pituitary gland is often called the "master gland" because it

- A. produces the largest amount of every hormone
- B. regulates the activity of many other endocrine glands
- C. is located in the center of the human chest cavity
- D. produces all of the body's red and white blood cells

PART B-1 — DATA-BASED MULTIPLE CHOICE (13 Questions, 13 Points)

Answer all questions in this part. Base your answers to questions 31–34 on the diagram below and on your knowledge of biology.

31. A student examines a detailed diagram of a mitochondrion.

Mitochondrion Cross-Section

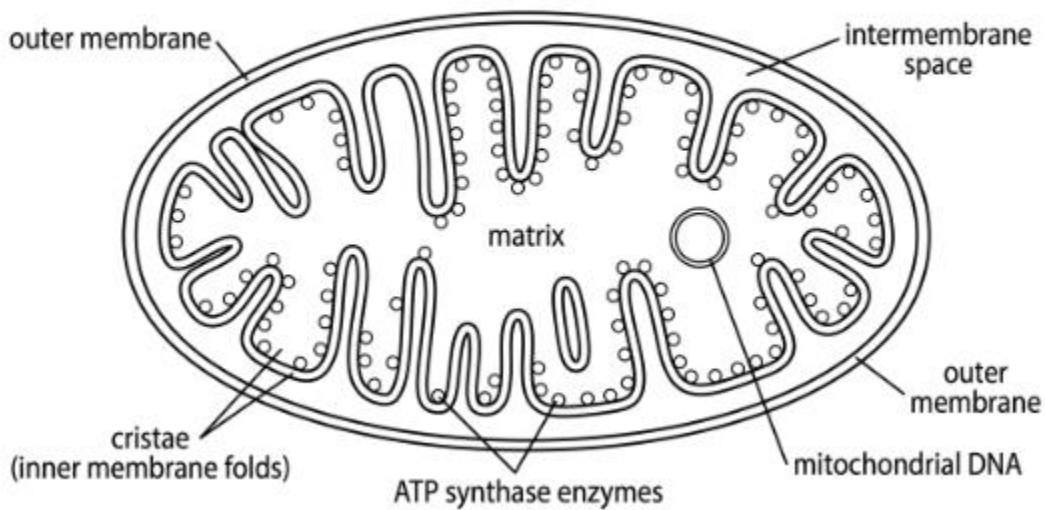

In the diagram, the folded inner membranes of the mitochondrion (cristae) function to

- A. store the mitochondrion's genetic information internally
- B. transport ATP molecules out of the cell entirely
- C. separate the inner and outer fluid compartments
- D. increase the surface area for ATP-producing reactions

32. Referring to the same diagram, the fluid-filled central compartment of the mitochondrion is identified as the

- A. cristae of the inner membrane structure
- B. intermembrane space between the two membranes
- C. matrix of the mitochondrion's interior
- D. outer membrane surrounding the organelle

33. Referring to the same diagram, the presence of mitochondrial DNA inside the organelle supports the idea that

- A. mitochondria descended from bacteria engulfed by an ancient cell
- B. mitochondria are completely independent organisms today
- C. all mitochondrial proteins are still produced in the nucleus
- D. mitochondria are exclusive to multicellular organisms only

34. Referring to the same diagram, the ATP synthase enzymes shown along the inner membrane function to

- A. produce mitochondrial DNA for organelle replication
- B. assemble ATP from ADP and inorganic phosphate
- C. break ATP down into glucose and oxygen molecules
- D. transport sodium ions out of the cell membrane

Base your answers to questions 35–37 on the graph below and on your knowledge of biology.

35. A student measures the rate of photosynthesis in a water plant at different light intensities.

Rate of Photosynthesis vs. Light Intensity in a Water Plant.

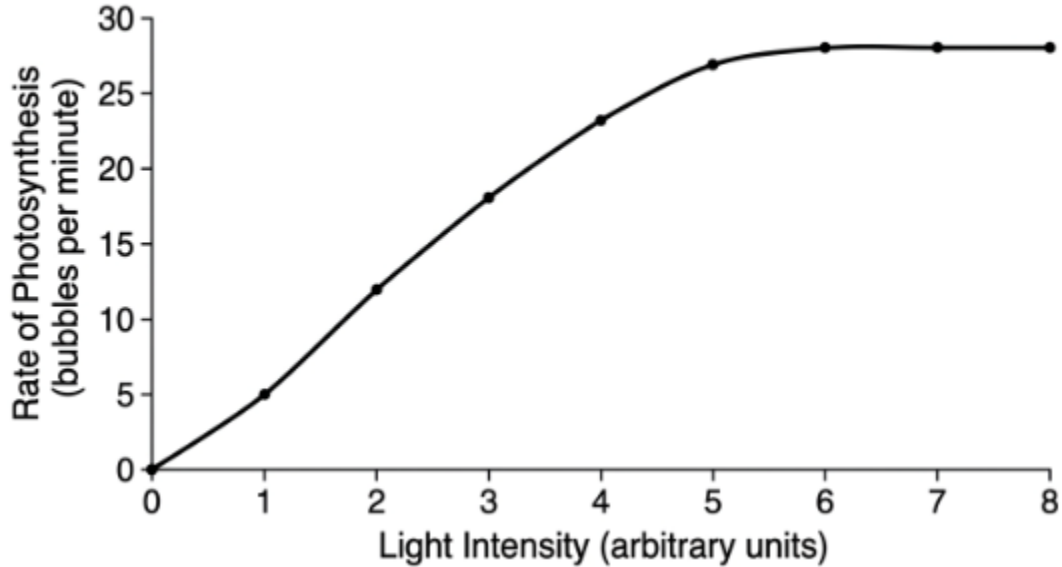

Based on the graph, the rate of photosynthesis reaches a plateau at a light intensity of approximately

- A. 2 units of light intensity on the graph
- B. 3 units of light intensity on the graph
- C. 4 units of light intensity on the graph
- D. 6 units of light intensity on the graph

36. Based on the same graph, the leveling off of the photosynthesis rate at high light intensities suggests that

- A. light is the only factor affecting photosynthesis here
- B. another factor such as CO₂ or temperature now limits the rate
- C. the plant has stopped photosynthesizing entirely now
- D. the plant is using less water at higher light intensities

37. Based on the same graph, if the student wished to increase the photosynthesis rate above the plateau value, the most useful experimental change would be to

- A. increase the carbon dioxide concentration around the plant
- B. decrease the temperature of the surrounding water
- C. remove all of the chlorophyll from the plant's leaves
- D. reduce the amount of light available to the plant

Base your answers to questions 38–40 on the pedigree below and on your knowledge of biology.

38. A pedigree shows the inheritance of sickle cell anemia, an autosomal recessive disorder, in a family.

Pedigree of Sickle Cell Anemia

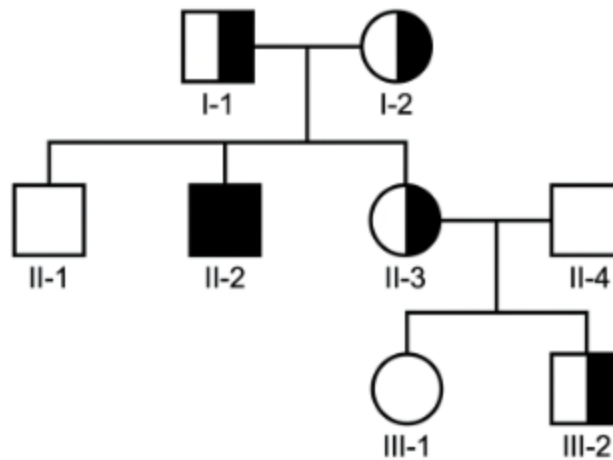

Filled = affected with sickle cell anemia; Half-filled = unaffected carrier;
Unfilled = unaffected non-carrier; Square = male; Circle = female.

Based on the pedigree, an unaffected non-carrier individual (such as II-4) must have the genotype

- A. ss , with two copies of the recessive allele

- B. Ss, with one normal and one recessive allele
- C. either SS or Ss, depending on the carrier status
- D. SS, with two copies of the dominant normal allele

39. Based on the same pedigree, the probability that any given child of two carrier parents (such as I-1 and I-2) will be affected with sickle cell anemia is

- A. 50% probability of being affected by the disorder
- B. 25% probability of being affected by the disorder
- C. 75% probability of being affected by the disorder
- D. 100% probability of being affected by the disorder

40. Based on the same pedigree, individuals who are heterozygous carriers (Ss) do not show sickle cell symptoms because

- A. the recessive allele has been corrected by the body
- B. they have not yet inherited the recessive allele
- C. the normal dominant allele provides enough functional protein
- D. they have been treated with medication to prevent symptoms

Base your answers to questions 41–43 on the diagram below and on your knowledge of biology.

41. A student examines a diagram of the water cycle.

The Water Cycle.

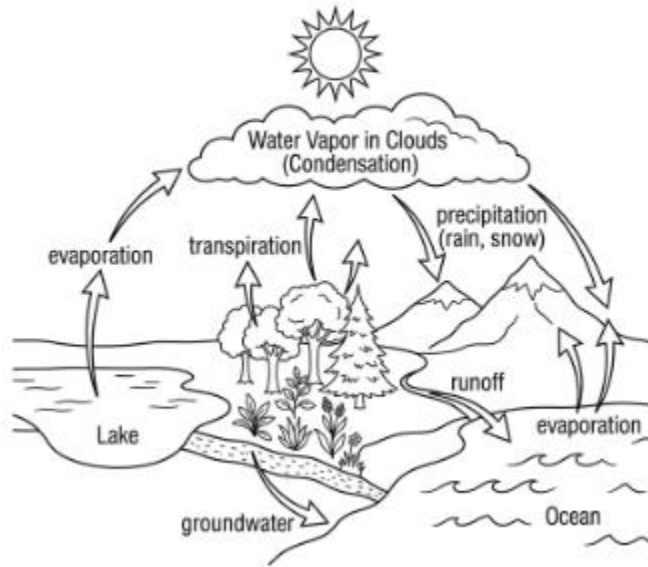

Based on the diagram, water enters the atmosphere primarily through

- A. evaporation from bodies of water and transpiration from plants
- B. condensation of water vapor into liquid droplets in clouds
- C. precipitation of rain and snow falling from the clouds
- D. runoff into rivers and lakes from the land surface

42. Based on the same diagram, water returns to the surface of Earth from the atmosphere through

- A. evaporation from oceans and lakes globally
- B. transpiration from the leaves of green plants
- C. groundwater flowing through underground rocks
- D. precipitation of rain, snow, and other forms

43. Based on the same diagram, the energy source that drives the water cycle is

- A. heat released from Earth's molten core
- B. solar energy radiating from the sun
- C. wind moving across the surface of the oceans
- D. chemical energy stored in the leaves of plants

PART B-2 — MIXED FORMAT (12 Questions, 12 Points)

Answer all questions in this part.

44. A scientist who designs an experiment to test whether a new fertilizer affects the growth of corn plants should compare the experimental group to

- A. a single corn plant grown in the previous growing year
- B. corn plants grown by a different scientist last season
- C. a control group of corn plants without the fertilizer added
- D. all of the corn plants in the surrounding community

45. After collecting data in an experiment, a scientist organizes the data and creates a graph. The next step in the scientific method would be to

- A. analyze the data and draw a conclusion based on the evidence
- B. discard the data if it does not match the original hypothesis

- C. publish the conclusion before performing any further analysis
- D. repeat the experiment without examining the data collected

46. The metric unit commonly used to measure the mass of a small object in a biology laboratory is

- A. milliliter (mL) for liquid mass measurement
- B. centimeter (cm) for measuring a length of mass
- C. gram (g) for measuring a small object's mass
- D. degree Celsius ($^{\circ}\text{C}$) for thermal mass measurement

47. In a DNA double helix, if one strand has the sequence 5'-ATCG-3', the complementary strand will have the sequence

- A. 5'-TAGC-3' running in the same direction as the first
- B. 5'-ATCG-3' the same as the first strand of DNA
- C. 5'-CGAT-3' running in the same direction as the first
- D. 5'-CGAT-3' running in the antiparallel direction

48. The process by which an organism breaks down food molecules to release energy is called

- A. anabolism, the building of larger molecules
- B. catabolism, the breakdown of larger molecules
- C. translation of mRNA into a protein chain
- D. transcription of DNA into RNA strands

49. A skin cell that no longer divides and is fully specialized to function as a skin cell has stopped at which phase of the cell cycle?

- A. G₀ phase, a non-dividing resting state
- B. M phase, in which mitosis is actively occurring
- C. S phase, in which DNA replication occurs
- D. G₂ phase, just before mitosis begins to occur

50. Two genes that are inherited together more often than expected by chance are described as being

- A. mutated by environmental exposure to chemicals
- B. duplicated copies of one another in the genome
- C. located on different homologous chromosomes
- D. linked on the same chromosome in the cell

51. The Hardy-Weinberg principle predicts that allele frequencies in a population will remain unchanged if

- A. natural selection is acting on the population
- B. random genetic drift is shifting allele frequencies
- C. no evolutionary forces are acting on the population
- D. members of the population mate non-randomly with each other

52. A scientist studies fossils and finds that older rock layers contain different species than younger layers. This pattern supports the conclusion that

- A. all species exist today exactly as they did in the past
- B. species change over time and new species can arise
- C. the fossil record contains no useful information about evolution
- D. all fossils are the same age and were buried at the same time

53. A new viral disease emerges in a human population. The initial public health response should include

- A. identifying the pathogen and how it is transmitted between people
- B. ignoring the outbreak until many more people are sick
- C. treating all infected patients with antibiotics immediately
- D. closing all schools and hospitals across the entire country

54. Antibiotic resistance in bacteria is an example of evolution because

- A. individual bacteria choose to develop resistance traits
- B. the use of antibiotics directly causes bacterial mutations
- C. resistant bacteria evolve from non-bacterial organisms
- D. bacteria with resistance alleles survive treatment and reproduce more

55. A keystone species in a coral reef ecosystem has been removed by overfishing. The most likely outcome over time is

- A. all other species in the reef will benefit from the change
- B. the ecosystem will remain stable as it was before the removal

- C. a sharp decrease in biodiversity and disruption to the reef
- D. the immediate evolution of new species to take its place

PART C — EXTENDED CONSTRUCTED RESPONSE (17 Questions, 17 Points)

Answer all questions in this part.

56. The cell cycle checkpoints exist mainly to ensure that

- A. each phase is completed correctly before the next begins
- B. cells divide as quickly as possible without monitoring
- C. every cell remains in interphase for the entire cycle
- D. cells with mutations always continue dividing rapidly

57. During anaphase of mitosis, the sister chromatids are pulled to opposite poles of the cell by the

- A. cell membrane contracting and dividing the cell
- B. spindle fibers attached at the centromere region
- C. ribosomes attached to the rough endoplasmic reticulum
- D. nuclear envelope reforming around each chromosome

58. A characteristic acquired during a person's lifetime, such as a callus on the hands from repeated work, is generally

- A. coded for in the person's gametes and passed to children
- B. inherited by all of the person's offspring at birth
- C. preserved in the person's DNA for future generations
- D. not passed on to the person's offspring genetically

59. In a species of fish, body color is determined by two genes, each with multiple alleles. The trait of body color is best described as

- A. a sex-linked trait found only on the X chromosome
- B. an environmentally acquired characteristic of the species
- C. a polygenic trait influenced by more than one gene
- D. a single-gene trait with only two possible alleles

60. An individual with the genotype $I^A B i$ for the ABO blood type would have the blood type

- A. type B, because $I^A B$ is expressed and i is recessive
- B. type A, because i is recessive to the $I^A B$ allele
- C. type O, because the i allele is fully expressed
- D. type AB, because both alleles are codominantly expressed

61. When a tundra ecosystem is altered by oil drilling activity, the recovery of the original community is usually very slow because

- A. the climate of the tundra is warm and humid all year

- B. tundra plants reproduce rapidly through their many seeds
- C. tundra soils contain a great deal of organic nutrients
- D. tundra growing seasons are very short and cold

62. A study finds that a particular forest contains many species of trees and supports a large number of bird, mammal, insect, and microbial species. This forest can be described as having a high level of

- A. abiotic factors only in the ecosystem
- B. biodiversity across multiple taxonomic groups
- C. competition between every pair of species
- D. predation rates of birds on small mammals

63. A population of insects in a field shows a wide range of body sizes. After spraying with an insecticide that is most effective against medium-sized insects, the surviving population contains mostly the smallest and largest individuals. This pattern is an example of

- A. directional selection toward one extreme of size
- B. stabilizing selection toward an intermediate size
- C. disruptive selection favoring two extremes of size
- D. artificial selection by a human breeder for size

64. The process by which different species develop similar traits because they live in similar environments is called

- A. convergent evolution, producing similar traits independently

- B. divergent evolution, producing different species from one ancestor
- C. coevolution between two species in close interaction
- D. artificial selection performed by humans on the species

65. The brain region responsible for coordinating voluntary muscle movements and maintaining balance is the

- A. cerebrum, the seat of conscious thought
- B. cerebellum, the coordinator of muscle activity
- C. brainstem, the control of vital functions
- D. spinal cord, the pathway for nerve signals

66. The valves of the heart function to

- A. produce the rhythmic contractions of the heart muscle
- B. supply oxygen-rich blood to the heart muscle tissue
- C. generate the electrical impulses for heart contractions
- D. prevent the backflow of blood between heart chambers

67. Oxygen and carbon dioxide are exchanged between the blood and the air at structures in the lungs called

- A. bronchi, which carry air to the lungs
- B. trachea, the main airway to the lungs

- C. alveoli, where the actual gas exchange occurs
- D. diaphragm, the muscle that moves the lungs

68. The wave-like contractions of smooth muscle that move food along the digestive tract are called

- A. peristalsis, occurring along the digestive tract
- B. mastication, occurring in the mouth area only
- C. emulsification, occurring with the help of bile
- D. absorption, occurring in the small intestine area

69. The functional unit of the kidney that filters the blood is the

- A. capillary that exchanges nutrients with cells
- B. neuron that transmits electrical signals quickly
- C. alveolus that exchanges gases with the air
- D. nephron that filters blood and concentrates urine

70. The major endocrine gland that produces hormones controlling the body's metabolic rate is the

- A. pancreas, controlling blood sugar levels by hormones
- B. adrenal gland, releasing adrenaline rapidly when stressed
- C. thyroid gland, producing thyroid hormones for metabolism
- D. parathyroid gland, controlling blood calcium levels closely

71. The two main types of cells that make up nervous tissue are

- A. epithelial cells and connective tissue cells
- B. neurons and supporting glial cells of the system
- C. red blood cells and white blood cells of the body
- D. smooth muscle cells and cardiac muscle cells

72. An organism's resistance to infection by viruses and bacteria is provided by its

- A. immune system, which fights off invading pathogens
- B. nervous system, which sends rapid electrical signals
- C. digestive system, which breaks down food into pieces
- D. circulatory system, which transports the blood

PART D — LABORATORY PRACTICAL (13 Questions, 13 Points)

Answer all questions in this part.

73. In the Beaks of Finches laboratory, a student who uses a clothespin tool to pick up small pieces of food represents a finch with

- A. an unusually large body size for its species
- B. a behavior that has been learned during its life
- C. a habitat that contains many different foods

D. a specific beak shape inherited from its parents

74. The Diffusion Through a Membrane laboratory demonstrates that small molecules can pass through a selectively permeable membrane while larger molecules cannot. This principle helps explain how

- A. cells reproduce by mitosis and cytokinesis steps
- B. enzymes catalyze biochemical reactions inside cells
- C. cells exchange materials with their surrounding environment
- D. cells transcribe DNA into mRNA inside the nucleus

75. When using a compound light microscope, a student should clean the lenses with

- A. a paper towel and water to remove all dust
- B. lens paper to avoid scratching the glass surface
- C. ordinary tissue paper with rubbing alcohol added
- D. a soft cotton cloth dipped in soapy water briefly

76. The Relationships and Biodiversity laboratory uses several techniques to determine evolutionary relationships among species. The simulated gel electrophoresis in this lab separates DNA fragments according to

- A. the size of each DNA fragment in the sample
- B. the temperature at which DNA breaks apart
- C. the color of each individual DNA fragment
- D. the number of cells the DNA came from originally

77. In the Making Connections laboratory, students discover that pulse rate generally increases during exercise. The biological reason for this increase is that

- A. exercise requires the body to slow its heart rate down
- B. exercise has no measurable effect on the heart muscle
- C. exercising muscles require more oxygen, demanding faster circulation
- D. the body produces less ATP during physical activity periods

78. A student observes onion cells stained with iodine solution under a compound microscope. The iodine solution is used in this preparation to

- A. kill any bacteria growing on the prepared slide
- B. preserve the onion cells for later use in lab
- C. magnify the cell structures by ten times the size
- D. stain cell structures so they are more easily visible

79. Before beginning a laboratory experiment, a student should always

- A. taste any liquids that have no warning labels on them
- B. read the entire procedure to know what to expect
- C. heat all materials regardless of the printed instructions
- D. throw away the safety goggles to see the work better

80. A student wants to measure the temperature of a solution during a laboratory experiment. The most appropriate instrument is

- A. a graduated cylinder calibrated in milliliters of liquid
- B. a triple beam balance measuring mass in grams accurately
- C. a thermometer marked in degrees Celsius for temperature
- D. a meter stick marked in centimeters and millimeters

81. A student conducting an experiment notices that the equipment is producing inconsistent readings. The student's best action is to

- A. recalibrate or replace the equipment and repeat the trials
- B. record only the readings that match the expected values
- C. ignore the inconsistent readings and continue collecting data
- D. report results based on a single trial of the experiment

82. A student wishes to graph data showing the population sizes of three different species over five years. The most appropriate type of graph would be

- A. a circle graph showing percentages of each species
- B. a single bar showing only the largest population over years
- C. a Venn diagram showing overlapping populations of species
- D. a line graph with each species as a separate plotted line

83. In the Beaks of Finches laboratory, the second round of feeding represents the next generation because

- A. students switch positions with their lab partners

- B. the food supply is restored to its initial amount
- C. the surviving "finches" pass their "beak" traits to offspring
- D. the laboratory begins again with all new participating students

84. In a biology laboratory, broken glass should be placed in

- A. the regular classroom trash can with all other waste
- B. a separate container clearly labeled for broken glass
- C. a paper bag inside the desk drawer for later disposal
- D. the recycling bin used for soda cans and bottles

85. The variable that the experimenter manipulates in a controlled experiment is called the

- A. independent variable, deliberately changed by the experimenter
- B. dependent variable, measured as the response to changes
- C. controlled variable, kept the same in both groups
- D. random variable, varying unpredictably between trials

ANSWER KEY WITH EXPLANATIONS – Practice Exam 21

1. C — Proteins serve as both structural components (collagen, keratin) and as enzymes that catalyze nearly every biochemical reaction in the cell. DNA stores genetic information, carbohydrates serve as energy, and only plant cell walls contain cellulose — none of these are the primary roles of protein. Proteins are the workhorses of the cell.

2. A — Carbohydrates such as glucose are quickly broken down through glycolysis and cellular respiration to release ATP, making them the body's preferred short-term energy source. Lipids store long-term energy,

nucleic acids store information, and proteins build structures. This is why athletes "carb-load" before endurance events.

3. B — The plasma membrane is built from a phospholipid bilayer with embedded proteins that serve as channels, receptors, and pumps. The hydrophilic heads face outward and the hydrophobic tails face inward, forming a stable selective barrier. This fluid mosaic structure controls all entry and exit of substances.

4. D — A hypotonic external solution has lower solute concentration than the cell interior, so water flows into the plant cell by osmosis. The cell wall prevents bursting, and the resulting internal water pressure (turgor) presses outward, keeping the plant upright. Loss of turgor causes wilting.

5. A — Muscle contraction requires enormous amounts of ATP to power myosin filaments sliding against actin. Mitochondria are the cell's ATP factories, so muscle cells contain hundreds to thousands of them. Endurance training increases mitochondrial number per muscle cell to improve energy output.

6. B — An inhibitor binds to an enzyme — either at the active site (competitive) or elsewhere (non-competitive) — and slows or stops the catalyzed reaction. Substrates are what enzymes act on, products are what they produce, and coenzymes assist enzyme activity rather than blocking it. Many drugs work by inhibiting specific enzymes.

7. D — The Calvin cycle takes place in the stroma, the fluid surrounding the thylakoid membranes inside the chloroplast. The stroma contains the enzymes (including RuBisCO) needed to fix CO₂ and synthesize glucose using ATP and NADPH made during the light reactions. The light reactions occur in the thylakoid membranes themselves.

8. B — Glycolysis, the first stage of cellular respiration, occurs in the cytoplasm and splits one glucose molecule into two pyruvates while generating a small amount of ATP and NADH. Unlike later stages, glycolysis does not require oxygen, which makes it the universal first step of energy extraction from glucose.

9. A — In alcoholic fermentation, yeast convert pyruvate to ethanol and release carbon dioxide as a waste product, regenerating NAD⁺ so glycolysis can continue. This process is the basis of brewing, winemaking, and bread rising. Without oxygen, fermentation is the only way these cells can keep producing ATP.

10. D — Uracil replaces thymine in RNA molecules, while DNA contains adenine, thymine, guanine, and cytosine. Both molecules share adenine, guanine, and cytosine, but only RNA contains uracil. This is one of the key chemical differences distinguishing the two nucleic acids.

11. C — Redundancy in the genetic code means more than one codon can specify the same amino acid — for example, leucine is coded by six different codons. With 64 possible codons and only 20 amino acids, multiple codons can map to the same amino acid. This redundancy buffers organisms against many single-base mutations.

12. B — The universality of the genetic code across bacteria, plants, animals, and humans is one of the strongest pieces of evidence that all life shares a single common ancestor. If life had arisen multiple times

independently, different lineages would use different codes. This shared code also makes recombinant DNA technology possible.

13. D — Mendel's law of segregation states that the two alleles for each gene separate during gamete formation, so each gamete carries only one allele per gene. When fertilization occurs, the offspring receives one allele from each parent, restoring the diploid combination. This law underlies all monohybrid crosses.

14. A — A test cross involves crossing the unknown individual with a homozygous recessive partner. If all offspring show the dominant phenotype, the unknown is homozygous dominant; if half show the recessive phenotype, the unknown is heterozygous. This is the classic technique for determining unknown genotypes.

15. C — Down syndrome (trisomy 21) is caused by nondisjunction during meiosis, leaving the affected individual with three copies of chromosome 21 instead of the usual two. Cystic fibrosis and sickle cell anemia are caused by gene-level mutations, and hemophilia is X-linked — none result from extra chromosomes. The extra chromosome 21 causes distinctive developmental features.

16. B — A $Tt \times Tt$ cross produces a genotype ratio of 1 TT : 2 Tt : 1 tt , giving a phenotype ratio of 3 dominant to 1 recessive. This 3:1 ratio is the classic Mendelian outcome of a heterozygous monohybrid cross with complete dominance. Mendel discovered this pattern through experiments with pea plants.

17. A — Darwin's theory of natural selection explains the giraffe's long neck as the result of differential survival and reproduction: ancestors with slightly longer necks could reach more food, survived to reproduce, and passed on the trait. Lamarck's idea of inherited acquired characteristics has been disproven, and traits do not develop through choice or willpower.

18. D — DNA sequence similarity provides the most precise molecular evidence of common ancestry, because closely related species have had less time to accumulate genetic differences since their last shared ancestor. Shared habitat, similar appearance, or shared community do not necessarily indicate close evolutionary relationship — only DNA comparisons measure ancestry directly.

19. C — Genetic drift is the random change in allele frequencies due to chance events, and it is particularly significant in small populations where chance has a larger relative effect than in large ones. Natural selection requires environmental pressure, and artificial selection requires human intervention — neither applies here. Drift can lead to fixation or loss of alleles regardless of their fitness.

20. A — Seasonal color change in Arctic foxes is a structural adaptation produced by natural selection, allowing the fox to blend with snow in winter and tundra vegetation in summer. Camouflage helps the fox avoid predators and ambush prey, increasing its survival and reproductive success. The change is hormonally triggered, not behaviorally chosen.

21. B — A population is defined as a group of individuals of the same species living in the same area and capable of interbreeding. A community includes multiple populations of different species, an ecosystem includes organisms plus their non-living environment, and the biosphere encompasses all life on Earth. Population is the fundamental unit of ecology.

22. D — A habitat is the specific physical location where an organism lives — a particular tree, pond, or stretch of soil. A niche includes not only habitat but also the organism's full ecological role (diet, behavior, interactions). The two terms are often confused but are distinct: habitat is the address, niche is the occupation.

23. C — Commensalism is a relationship in which one species benefits while the other is neither helped nor harmed. Barnacles gain transportation and access to nutrient-rich waters by riding on whales, but the whales are essentially unaffected. This contrasts with mutualism (both benefit) and parasitism (one benefits, one is harmed).

24. A — Approximately 10% of energy transfers from one trophic level to the next, so primary consumers receive about 10% of the producer's energy. 10% of 10,000 kilocalories is 1,000 kilocalories. The remaining 9,000 kilocalories are lost as heat, used by the producers themselves, or remain in inedible plant parts.

25. B — In aquatic ecosystems, sunlight is rapidly attenuated by water and dissolved particles, so light availability is typically the most limiting factor for photosynthetic producers below the surface. This is why phytoplankton concentrate in the upper photic zone and why deep waters support no primary production. Nutrients are also important but are secondary in many systems.

26. C — Ecological succession is the gradual, predictable replacement of one community by another over time. The pond-to-meadow-to-forest progression is a classic example of pond succession, where sediment fills the basin and supports successively larger plant communities. Each stage modifies the environment in ways that favor the next.

27. D — Eutrophication occurs when excess nutrients (often from fertilizer runoff) cause rapid algal blooms. When the algae die, decomposers consume large amounts of dissolved oxygen, leading to dead zones where fish and other aquatic animals suffocate. This is a major form of water pollution worldwide.

28. A — Carrying capacity (**K**) is the maximum sustainable population size that an environment can support indefinitely given available resources. Populations growing exponentially eventually slow and stabilize at **K** because of limiting factors like food, water, and space. Above **K**, mortality increases and populations crash.

29. C — Sweat evaporation requires heat energy, which is drawn from the skin and underlying tissues, cooling the body. This evaporative cooling is the primary mechanism humans use to dissipate excess heat during exercise. It works less well in humid conditions because evaporation is slowed.

30. B — The anterior pituitary gland produces tropic hormones (TSH, ACTH, FSH, LH) that regulate the thyroid, adrenal cortex, and gonads, among other glands. Because it controls so many other endocrine glands, it has earned the nickname "master gland." It is itself regulated by the hypothalamus through releasing hormones.

31. D — Cristae are the folded inner membranes of mitochondria, and their folding dramatically increases the surface area available for the electron transport chain enzymes embedded in them. More surface area

means more ATP synthase complexes and more ATP production. This structural design maximizes the cell's energy output per organelle.

32. C — The matrix is the fluid-filled central compartment of the mitochondrion, surrounded by the inner membrane. It contains the enzymes of the Krebs cycle, mitochondrial DNA, ribosomes, and various cofactors. The matrix is the site where pyruvate is oxidized and many CO₂ molecules are released.

33. A — Mitochondria contain their own circular DNA, ribosomes, and double membrane — features they share with bacteria. This evidence supports the endosymbiotic theory, which proposes that mitochondria descended from free-living bacteria that were engulfed by an ancestral eukaryotic cell. Chloroplasts likely arose by a similar process.

34. B — ATP synthase enzymes use the energy stored in the proton gradient across the inner mitochondrial membrane to assemble ATP from ADP and inorganic phosphate. This process, called chemiosmosis, accounts for most of the ATP produced in aerobic respiration. The flow of protons through ATP synthase drives a rotational mechanism that synthesizes ATP.

35. D — The graph levels off at approximately 28 bubbles per minute beginning around light intensity 6, after which additional light produces no further increase. This plateau represents the maximum rate that the plant can sustain under the current conditions. Light is no longer the limiting factor at this point.

36. B — When the rate stops responding to additional light, some other factor — most commonly CO₂ concentration, temperature, or chlorophyll availability — has become the new limiting factor. The plant cannot use additional light if it lacks the raw materials or conditions needed to keep the chemistry going. This is an example of Liebig's law of the minimum.

37. A — Once light is saturating, increasing CO₂ removes the next likely bottleneck and allows the rate to climb to a new plateau. Decreasing temperature would slow the reactions, and removing chlorophyll would stop photosynthesis entirely. CO₂ supplementation is used commercially in greenhouses to boost crop production.

38. D — Sickle cell anemia is autosomal recessive, so an unaffected non-carrier must be homozygous for the dominant normal allele (SS). Carriers have the genotype Ss, and affected individuals have ss. Only SS individuals have no copies of the disease allele and cannot pass it on.

39. B — A Ss × Ss cross produces offspring in a 1 SS : 2 Ss : 1 ss genotype ratio, so each child has a 1 in 4 (25%) chance of being homozygous recessive and affected. The remaining 75% will be unaffected — either as carriers (50%) or as non-carriers (25%). This is the standard outcome of two carrier parents.

40. C — Carriers (heterozygotes) have one normal S allele and one disease s allele. The dominant S allele produces enough functional hemoglobin to prevent sickle cell symptoms under normal conditions. Carriers may show partial sickling under extreme low-oxygen stress but generally lead healthy lives — a phenomenon known as sickle cell trait.

41. A — Water enters the atmosphere through evaporation from oceans, lakes, and rivers, and through transpiration from plant leaves. Together these processes are sometimes called "evapotranspiration." Both depend on solar energy to convert liquid water into water vapor.

42. D — Precipitation — rain, snow, sleet, and hail — is the process that returns water from the atmosphere to Earth's surface. Once on the surface, water either runs off into bodies of water, soaks into the soil as groundwater, or evaporates again. Precipitation completes the atmospheric portion of the water cycle.

43. B — Solar energy heats surface water, causing evaporation, and drives the winds that move water vapor through the atmosphere. Without sunlight, evaporation and most weather patterns would cease. The sun is therefore the engine of the entire water cycle.

44. C — A control group of corn plants grown identically but without the fertilizer provides the baseline against which the experimental group can be compared. Without a proper control, differences in growth could not be attributed specifically to the fertilizer. A control is essential for establishing causation in any experiment.

45. A — After organizing data, the scientific method calls for analyzing the data and drawing a conclusion based on what the evidence shows. Conclusions must be based on data, not on what the experimenter wanted to find. This step turns raw measurements into meaningful scientific knowledge.

46. C — Mass is measured in grams (or kilograms for larger objects) using a triple-beam balance or electronic scale. Milliliters measure volume, centimeters measure length, and degrees Celsius measure temperature — none of these are mass units. The gram is the standard metric unit for small object mass in laboratory work.

47. D — Complementary base pairing means A pairs with T and G pairs with C, so 5'-ATCG-3' pairs with 3'-TAGC-5', which reads 5'-CGAT-3' in the antiparallel direction. The two strands of a DNA molecule always run in opposite directions because the sugar-phosphate backbone has a defined 5' and 3' end.

48. B — Catabolism encompasses all metabolic reactions that break down larger molecules into smaller ones, releasing energy in the process. Cellular respiration is the most important catabolic process in cells. Anabolism, the opposite, builds larger molecules and consumes energy.

49. A — Cells that have permanently exited the cell cycle and become fully specialized enter the G₀ (G-zero) phase, a non-dividing resting state. Most mature human cells, including nerve and most skin cells, are in G₀. Cells in G₀ carry out their specialized functions but do not replicate DNA or divide.

50. D — Genetic linkage occurs when two genes are located close enough together on the same chromosome that they tend to be inherited together, violating Mendel's law of independent assortment. The closer the two genes, the tighter the linkage. Geneticists use recombination frequency to map gene positions along chromosomes.

51. C — The Hardy-Weinberg equilibrium holds only when no evolutionary forces are at work: no mutation, no migration, no natural selection, no genetic drift, and random mating. If any of these

conditions is violated, allele frequencies will change and the population is evolving. The principle therefore serves as a null model against which evolution can be detected.

52. B — The differing species in older versus younger rock layers show that species change over time and that new species can arise. This is one of the most important pieces of evidence for evolution and underlies the entire fossil record. The order of fossils in rock strata reveals the sequence of evolutionary change.

53. A — The first step in responding to any emerging disease outbreak is to identify the pathogen and learn how it is transmitted, because effective countermeasures depend on understanding what is causing the disease and how it spreads. Antibiotics are useless against viruses, and broad school and hospital closures would be premature without understanding the threat.

54. D — Bacteria with pre-existing resistance alleles survive antibiotic exposure while susceptible bacteria die, leaving the resistant ones to reproduce and pass their genes to subsequent generations. Over time, the population becomes mostly resistant. This is classic natural selection acting on bacterial populations and is the reason antibiotic stewardship is so important.

55. C — Removing a keystone species causes disproportionate effects on the community because that species disproportionately controlled the structure or composition of the ecosystem. The loss often cascades through the food web, reducing biodiversity and disrupting ecosystem services. Coral reefs and kelp forests are particularly vulnerable to keystone removal.

56. A — Cell cycle checkpoints verify that DNA is undamaged, chromosomes are properly attached, and required materials are present before allowing the cycle to advance. Failure of checkpoints can lead to uncontrolled division and is one of the underlying mechanisms of cancer. Checkpoints are the cell's quality control system.

57. B — Spindle fibers (microtubules) attach to the centromere region of each chromosome at the kinetochore. During anaphase, these fibers shorten, pulling sister chromatids toward opposite poles of the cell. This separation ensures that each daughter cell receives a complete set of chromosomes.

58. D — Acquired characteristics result from environmental influences on a person's body but do not change the DNA in the gametes, so they are not heritable. Calluses, scars, and learned behaviors are not passed to offspring. This understanding refuted Lamarck's earlier "inheritance of acquired characteristics" theory.

59. C — A polygenic trait is one influenced by two or more genes acting together. Body color determined by two genes with multiple alleles fits this definition. Polygenic traits typically show continuous variation rather than discrete categories, which is why human traits like height and skin color show wide ranges of variation.

60. A — The I^A and I^B alleles are codominant, while i is recessive to both. The genotype $I^B i$ expresses only the I^B allele because i is recessive, producing blood type B. This individual's red blood cells carry the B antigen but not the A antigen on their surface.

61. D — Tundra recovery is slow because the growing season is only a few weeks long, temperatures remain low, and decomposition of organic matter occurs slowly. New plants take many years to establish, and the permafrost limits root growth. Damage from human activity in the tundra can persist for decades or centuries.

62. B — Biodiversity refers to the variety of species, genetic diversity, and ecosystem types within an area, across multiple taxonomic groups. A forest with many tree, bird, mammal, insect, and microbial species clearly exhibits high biodiversity. High biodiversity often correlates with ecosystem stability and resilience.

63. C — Disruptive selection favors both extremes of a trait while selecting against intermediates. When medium-sized insects die from the insecticide, the smallest and largest survive disproportionately. This is one of the three main modes of selection along with directional and stabilizing selection.

64. A — Convergent evolution produces similar traits in unrelated species facing similar environmental pressures. Streamlined body shapes in dolphins and sharks, and wings in birds and bats, are classic examples. Convergent evolution does not imply common ancestry — only that natural selection finds similar solutions to similar problems.

65. B — The cerebellum, located at the back of the brain, coordinates voluntary muscle movements and maintains balance and posture. Damage to the cerebellum causes uncoordinated movements (ataxia) and difficulty maintaining balance. The cerebrum handles higher-order thought, while the brainstem controls vital functions.

66. D — Heart valves are one-way structures that prevent blood from flowing backward between the chambers of the heart. The atrioventricular valves (mitral and tricuspid) separate atria from ventricles, and the semilunar valves (aortic and pulmonary) prevent backflow into the ventricles after they pump. Valve dysfunction causes serious heart conditions like regurgitation or stenosis.

67. C — Alveoli are tiny air sacs in the lungs where oxygen diffuses into the blood and carbon dioxide diffuses out. Their thin walls and vast surface area make them ideal for rapid gas exchange. The bronchi, trachea, and diaphragm support breathing but do not perform the actual gas exchange.

68. A — Peristalsis is the wave-like contraction of smooth muscle along the digestive tract that propels food from the esophagus through the stomach and intestines. This involuntary motion ensures the smooth one-way movement of food regardless of body position. It is why astronauts can swallow normally in zero gravity.

69. D — The nephron is the functional filtering unit of the kidney, with each kidney containing about one million nephrons. Blood is filtered in the glomerulus, and the filtrate passes through tubules where water and useful substances are reabsorbed, leaving urine. Damage to nephrons impairs the body's ability to remove wastes.

70. C — The thyroid gland produces thyroid hormones (T_3 and T_4) that regulate the body's overall metabolic rate, affecting nearly every tissue. An underactive thyroid (hypothyroidism) slows metabolism,

while an overactive thyroid (hyperthyroidism) speeds it up. The thyroid is regulated by TSH from the pituitary.

71. B — Nervous tissue consists primarily of neurons, which transmit electrical signals, and supporting glial cells (astrocytes, oligodendrocytes, Schwann cells), which provide structure, insulation, and nutritional support. Glial cells outnumber neurons in many parts of the brain. The other cell types listed belong to different tissues.

72. A — The immune system, including white blood cells, antibodies, and lymphoid organs, provides the body's resistance to viral and bacterial infection. It recognizes and destroys pathogens through both innate and adaptive responses. Disorders such as HIV/AIDS that damage the immune system leave people vulnerable to many infections.

73. D — In the Beaks of Finches simulation, each tool represents a specific beak shape that the simulated finch has inherited from its parents. The simulation demonstrates how heritable variations in physical traits affect feeding success. This is the core of the natural selection lesson.

74. C — Selective permeability allows cells to exchange necessary materials — gases, nutrients, ions, and waste products — with their surroundings while excluding harmful or unneeded substances. This principle is fundamental to membrane biology and is the basis of cellular homeostasis. The dialysis tubing in the lab models the cell membrane.

75. B — Microscope lenses are coated with delicate optical materials that can be scratched by ordinary paper or cloth. Lens paper is specifically designed to clean lenses without damaging them. Rough materials, soap, and water can leave residues or scratches that permanently impair the lens quality.

76. A — Gel electrophoresis separates DNA fragments by size: shorter fragments move faster through the gel and travel farther in a given time. The electrical field draws the negatively charged DNA toward the positive electrode, but the gel matrix acts as a sieve that holds larger fragments back. The result is a banded pattern that allows DNA comparison.

77. C — Active muscles consume oxygen and glucose rapidly to produce ATP for contraction, so the heart must beat faster to deliver more oxygenated blood and remove waste CO₂. The increased pulse rate is a direct homeostatic response to higher metabolic demand. It is one of the most easily observed physiological responses to exercise.

78. D — Iodine is a stain that binds to and darkens cellular structures, particularly the nuclei and cell walls of onion epidermal cells. Without staining, these structures are nearly transparent and difficult to see under the microscope. Staining is a routine technique in microscopy to improve visibility of specimens.

79. B — Reading the entire procedure before starting an experiment helps the student anticipate hazards, gather all needed materials, and avoid critical errors that can affect results or safety. Tasting unknown chemicals, heating against instructions, or removing safety equipment are all dangerous practices. Preparation is the first rule of lab safety.

80. C — A thermometer marked in degrees Celsius is the standard instrument for measuring temperature in the biology laboratory. Graduated cylinders measure volume, balances measure mass, and meter sticks measure length — none of these measure temperature. Choosing the correct instrument is essential for valid measurement.

81. A — Inconsistent equipment readings indicate a problem with the instrument that must be addressed before reliable data can be collected. Recalibrating or replacing the equipment and repeating trials produces trustworthy results. Ignoring or cherry-picking readings would compromise the experiment's scientific integrity.

82. D — A line graph with separate lines for each species clearly shows how the population size of each species changes over the five-year period and allows direct visual comparison among them. Circle graphs and single bars cannot display change over time, and Venn diagrams show overlap, not population sizes. Line graphs are the standard for continuous data over time.

83. C — In the second round, the surviving "finches" represent the next generation that has inherited the successful "beak" traits from the previous round's survivors. Less successful "finches" are removed, just as natural selection removes less successful individuals from real populations. This simulates inheritance and the next generation's gene pool.

84. B — Broken glass poses a serious cut hazard if mixed with regular trash, where someone might be cut while emptying the can. A clearly labeled separate container alerts custodial staff to handle the contents with care. This is standard laboratory waste management protocol.

85. A — The independent variable is the variable that the experimenter deliberately changes or manipulates to test its effect. The dependent variable changes in response, and controlled variables are kept constant. Properly identifying these variables is the foundation of any controlled experiment.