

PRACTICE EXAM 12: FE ELECTRICAL AND COMPUTER SIMULATION (110 QUESTIONS)

Time allotted: 5 hours 20 minutes

Materials: NCEES-approved calculator + NCEES FE Reference Handbook only

1. What is the derivative of $f(x) = 5x^3 - 2x$?

- A. $15x^2 + 2$
- B. $5x^2 - 2$
- C. $15x^2 - 2$
- D. $15x^3 - 2$

2. Evaluate $\int x^3 dx$.

- A. $x^4/4 + C$
- B. $3x^2 + C$
- C. $x^4 + C$
- D. $4x^4 + C$

3. Evaluate j^3 , where $j = \sqrt{-1}$.

- A. j
- B. 1

C. -1

D. $-j$

4. The solutions of $\cos(x) = 0$ over the interval $[0, 2\pi)$ are:

A. $x = 0$ and $x = \pi$

B. $x = \pi/2$ and $x = 3\pi/2$

C. $x = \pi/4$ and $x = 5\pi/4$

D. $x = \pi$ only

5. Evaluate the determinant of the matrix with rows $[1, 2]$ and $[3, 4]$.

A. 10

B. 2

C. -2

D. 4

6. The derivative of $f(x) = e^{-x}$ is:

A. e^{-x}

B. $x \cdot e^{-x}$

C. $-e^x$

D. $-e^{-x}$

7. Convert 0.75 to a fraction in lowest terms.

A. $3/4$

B. $7/5$

C. $3/5$

D. $75/10$

8. The integral $\int_1^e (1/x) dx$ equals:

A. e

B. $e - 1$

C. 0

D. 1

9. The vector $A = 2i + 3j$ makes an angle with the positive x-axis of approximately:

A. 33.69°

B. 45.00°

C. 30.00°

D. 56.31°

10. The value of $\sin(30^\circ) + \cos(60^\circ)$ is:

A. 0

B. 0.5

C. 1

D. 1.5

11. The concept of a radius of convergence applies to a:

A. Power series

B. Single polynomial term

C. Definite integral

D. System of linear equations

12. If $y = 3x^2$ and x increases from 2 to 2.01, the approximate change in y using differentials ($dy = 6x \cdot dx$) is:

A. 0.6

B. 0.012

C. 0.12

D. 1.2

13. A bag has 10 chips numbered 1–10. What is the probability of drawing a prime number?

A. $3/10$

B. $2/5$

C. $1/2$

D. $1/5$

14. The median of the data set 2, 5, 8, 11 is:

A. 5

B. 6.5

C. 8

D. 7

15. The probability of an impossible event is:

A. 0

B. 1

C. 0.5

D. Undefined

16. A fair coin is tossed twice. What is the probability of getting at least one head?

A. $1/4$

B. $1/2$

C. $3/4$

D. 1

17. The expected value of rolling a single fair six-sided die is:

A. 6

B. 1

C. 3

D. 3.5

18. Under the NSPE Code, an engineer's obligation to maintain client confidentiality:

A. Ends immediately when the project is completed

B. Continues even after the business relationship ends

C. Applies only to written documents, not conversations

D. May be waived if a competitor offers a higher fee

19. A client asks an engineer to use a cheaper material that does not meet the required safety code. The engineer should:

A. Refuse and insist on code-compliant materials

B. Comply since the client accepts responsibility

- C. Use the cheaper material only in hidden areas
- D. Comply but document the objection privately

20. Under the NSPE Code, giving or receiving a bribe to secure work is:

- A. Permitted if disclosed to the employer afterward
- B. Permitted when it is customary in the region
- C. Strictly prohibited as unethical conduct
- D. Permitted for projects below a certain value

21. The NSPE obligation that engineers "issue no statements that contain a misrepresentation of fact" most directly supports the value of:

- A. Profitability in business dealings
- B. Honesty and truthfulness in the profession
- C. Loyalty to a single employer
- D. Speed of project completion

22. At 8% annual interest compounded annually, approximately how long does it take money to double (Rule of 72)?

- A. 8 years
- B. 4 years
- C. 16 years
- D. 9 years

23. The present worth of \$1,000 to be received in 1 year at a 25% discount rate is:

- A. \$1,250

- B. \$750
- C. \$800
- D. \$1,000

24. Money set aside today to accumulate to a target future amount through periodic deposits is described by which factor?

- A. Sinking fund factor
- B. Capital recovery factor
- C. Single-payment present-worth factor
- D. Gradient series factor

25. An expense that does not vary with the level of production output is classified as a:

- A. Variable cost
- B. Fixed cost
- C. Marginal cost
- D. Incremental cost

26. The payback period of an investment is the time required to:

- A. Earn a return equal to the MARR each year
- B. Fully depreciate the asset's first cost
- C. Double the original invested capital
- D. Recover the initial investment from net cash flows

27. Annealing a metal conductor generally:

- A. Reduces its resistivity by relieving lattice defects

- B. Permanently doubles its resistivity
- C. Converts it into a semiconductor material
- D. Has no effect on its electrical properties

28. The number of valence electrons in a silicon atom is:

- A. 2
- B. 8
- C. 4
- D. 1

29. The breakdown of a dielectric material occurs when the applied electric field:

- A. Drops below the material's rated minimum
- B. Exceeds the material's dielectric strength
- C. Alternates at exactly the resonant frequency
- D. Equals the material's relative permittivity

30. The reluctance of a magnetic circuit is analogous to which quantity in an electric circuit?

- A. Voltage
- B. Resistance
- C. Current
- D. Capacitance

31. A $20\ \Omega$ and a $30\ \Omega$ resistor are connected in parallel. The equivalent resistance is:

- A. $50\ \Omega$

- B. 25Ω
- C. 10Ω
- D. 12Ω

32. The energy stored in a 2 H inductor carrying 3 A is:

- A. 3 J
- B. 6 J
- C. 9 J
- D. 18 J

33. In a DC circuit at steady state, an ideal capacitor behaves as a(n):

- A. Open circuit
- B. Short circuit
- C. Constant current source
- D. Negative resistance

34. A current of 2 A flows through a 5Ω resistor for 10 seconds. The energy dissipated is:

- A. 100 J
- B. 200 J
- C. 50 J
- D. 20 J

35. In the resistor network shown, what is the total resistance between terminals X and Y?

Figure PQ-1

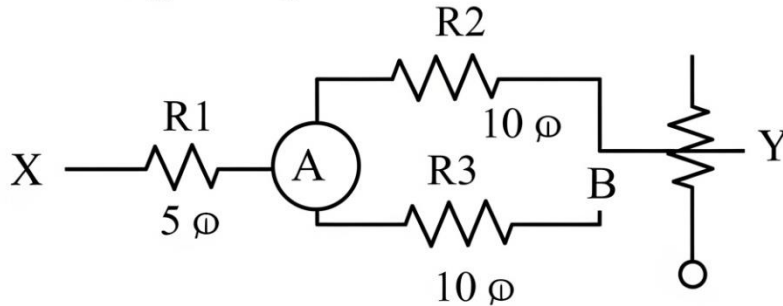

- A. 25 Ω
- B. 15 Ω
- C. 5 Ω
- D. 10 Ω

36. The phasor representation of a sinusoid captures its:

- A. Magnitude and phase at a fixed frequency
- B. Instantaneous value at every time instant
- C. Total energy over one complete cycle
- D. Frequency spectrum across all frequencies

37. A 1 A current source is connected in parallel with a 10 Ω resistor. The Thévenin equivalent voltage at the terminals is:

- A. 1 V
- B. 0.1 V
- C. 10 V

D. 100 V

38. The susceptance of a circuit is the imaginary part of its:

A. Impedance

B. Resistance

C. Reactance

D. Admittance

39. When two capacitors of equal value C are connected in series, the equivalent capacitance is:

A. $2C$

B. $C/2$

C. C

D. C^2

40. A sinusoidal current $i(t) = 5 \cdot \sin(\omega t)$ A has an RMS value of:

A. 5 A

B. 10 A

C. 3.54 A

D. 2.5 A

41. The voltage and current in a pure resistor are:

A. 90° out of phase

B. 180° out of phase

C. Exactly in phase

D. 45° out of phase

42. The time required for a charging RC circuit to reach approximately 99% of its final value is about:

- A. One time constant
- B. Five time constants
- C. Ten time constants
- D. One-half time constant

43. The current through a $6\ \Omega$ resistor that dissipates 24 W is:

- A. 2 A
- B. 4 A
- C. 6 A
- D. 144 A

44. The Laplace transform of the derivative $f'(t)$, with zero initial conditions, is:

- A. $F(s)/s$
- B. $1/F(s)$
- C. $F(s) + s$
- D. $s \cdot F(s)$

45. A transfer function has all of its poles in the left-half s-plane. The system is:

- A. Unstable
- B. Marginally stable
- C. Stable

D. Oscillatory without bound

46. Convolution in the time domain corresponds to _____ in the frequency domain.

A. Multiplication

B. Convolution

C. Addition

D. Differentiation

47. The discrete-time unit step sequence $u[n]$ is equal to:

A. 1 for all n

B. 1 for $n \geq 0$ and 0 for $n < 0$

C. 0 for all n

D. n for $n \geq 0$

48. A signal must be sampled at a rate higher than _____ to avoid aliasing.

A. The signal's lowest frequency

B. Exactly the signal's highest frequency

C. Half the signal's highest frequency

D. Twice the signal's highest frequency

49. The order of a filter generally determines its:

A. Center frequency only

B. Maximum input voltage

C. Steepness of roll-off near cutoff

D. Total power consumption

50. A causal system's impulse response $h(t)$ satisfies:

A. $h(t) = h(-t)$ for all time

B. $h(t) = 0$ for $t < 0$

C. $h(t) = 0$ for $t > 0$

D. $h(t)$ is constant for all t

51. The frequency content of a periodic square wave consists of:

A. The fundamental plus odd harmonics

B. The fundamental plus even harmonics only

C. A single sinusoid at the fundamental

D. A continuous band of all frequencies

52. A digital signal processor performs operations on signals that are:

A. Continuous in both time and amplitude

B. Continuous in time, discrete in amplitude

C. Discrete in time, continuous in amplitude

D. Discrete in both time and amplitude

53. The response of a first-order low-pass filter to a step input is:

A. A sustained oscillation at the cutoff frequency

B. An exponential rise toward the final value

C. An instantaneous jump to the final value

D. A linear ramp increasing without bound

54. The magnitude of a system's frequency response at a given frequency represents the:

- A. Time delay imposed on that frequency
- B. Phase shift introduced at that frequency
- C. Gain (amplification) applied at that frequency
- D. Total energy of the input at that frequency

55. Two systems connected in parallel have an overall transfer function equal to the:

- A. Sum of their individual transfer functions
- B. Product of their individual transfer functions
- C. Difference of their transfer functions
- D. Ratio of their transfer functions

56. In a non-inverting op-amp amplifier, the input signal is applied to the:

- A. Inverting input through a series resistor
- B. Output terminal via the feedback path
- C. Power supply rail of the device
- D. Non-inverting input terminal

57. The depletion region of a p-n junction widens when the junction is:

- A. Forward biased above the threshold
- B. Operated at exactly zero bias
- C. Reverse biased

D. Carrying its maximum forward current

58. A common application of a Zener diode is as a:

- A. High-frequency signal rectifier
- B. Voltage reference or regulator
- C. Variable resistor element
- D. Logic-level inverter stage

59. The current gain of a transistor in the common-base configuration (α) is:

- A. Slightly less than 1
- B. Much greater than 100
- C. Exactly equal to β
- D. Always negative

60. An ideal diode in the forward-biased (on) state behaves as a:

- A. Open circuit
- B. Constant current source
- C. Fixed resistor of $1\text{ k}\Omega$
- D. Short circuit (zero voltage drop)

61. The slew rate of an operational amplifier limits the:

- A. Maximum DC output voltage level
- B. Maximum rate of change of the output voltage
- C. Total input bias current allowed

D. Lowest frequency the amplifier can pass

62. In a logic family, the term "fan-out" refers to the:

- A. Speed at which a gate switches states
- B. Power consumed by a gate when idle
- C. Number of gate inputs one output can drive
- D. Physical size of the gate package

63. The figure shows the output characteristics of a transistor with a load line drawn. What is the collector current I_C at the quiescent (Q) operating point?

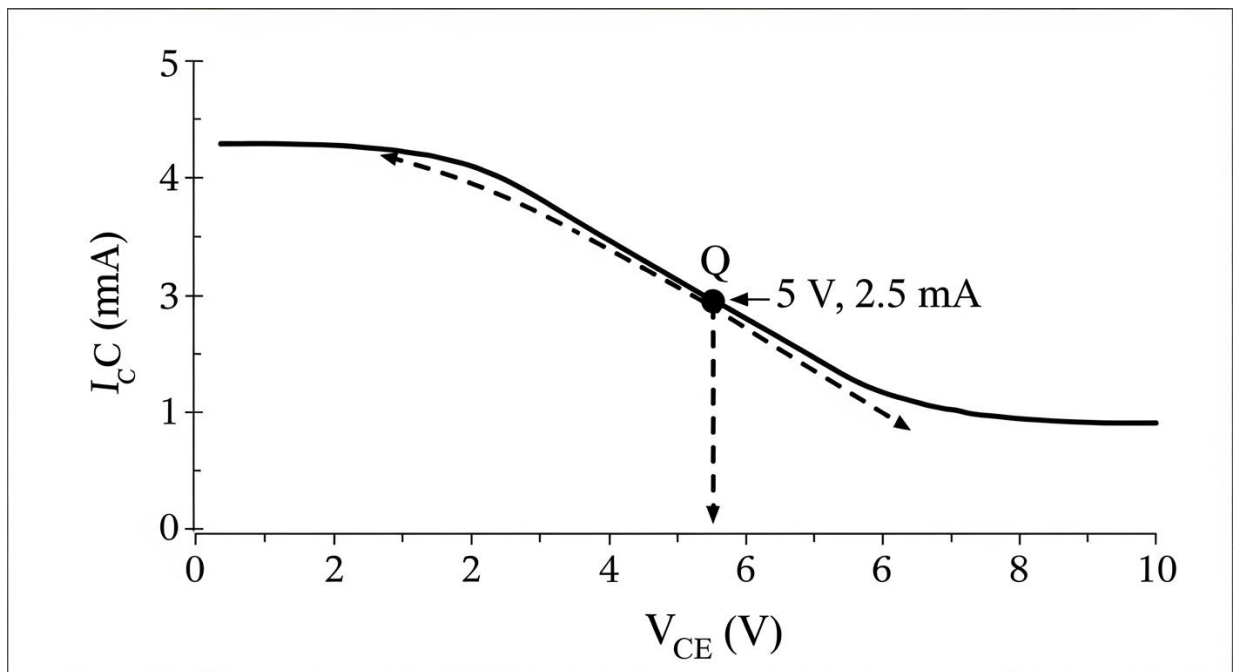

- A. 2.5 mA
- B. 5 mA
- C. 1.25 mA
- D. 10 mA

64. A 2,400/240 V transformer has a turns ratio of:

- A. 1:10
- B. 5:1
- C. 1:5
- D. 10:1

65. The real power consumed by a purely reactive (lossless) load is:

- A. Equal to the apparent power
- B. Zero
- C. Equal to the reactive power
- D. Maximum at resonance

66. A three-phase system is preferred over single-phase for power distribution because it:

- A. Delivers constant power and uses conductors more efficiently
- B. Requires only a single conductor for transmission
- C. Eliminates the need for any transformers
- D. Operates at a much lower frequency than single-phase

67. The synchronous speed of a 60 Hz, 2-pole machine is:

- A. 1800 rpm
- B. 900 rpm
- C. 3600 rpm
- D. 1200 rpm

68. A motor nameplate lists its "service factor." This value indicates the:

- A. Minimum voltage required to start the motor
- B. Ratio of input power to output power
- C. Number of poles in the stator winding
- D. Permissible overload the motor can handle continuously

69. To reverse the direction of rotation of a three-phase induction motor, one should:

- A. Swap any two of the three supply line connections
- B. Reverse the polarity of the neutral conductor
- C. Double the frequency of the supply voltage
- D. Disconnect one of the three phases entirely

70. A load draws 5 kW at a power factor of 0.8 lagging. The apparent power is:

- A. 4 kVA
- B. 6.25 kVA
- C. 5 kVA
- D. 8 kVA

71. The primary purpose of a circuit breaker in a power system is to:

- A. Improve the system power factor
- B. Step the voltage up for transmission
- C. Convert AC power into DC power
- D. Interrupt fault currents to protect equipment

72. A synchronous motor can be operated to supply reactive power to the grid by:

- A. Reducing its mechanical load to zero
- B. Lowering the supply frequency slightly
- C. Over-exciting its field winding
- D. Reversing two of its stator phases

73. The magnetic flux density B and magnetic field intensity H in a linear medium are related by:

- A. $B = H/\mu$
- B. $B = \mu H$
- C. $B = H^2$
- D. $B = \mu/H$

74. The work done in moving a charge between two points in an electrostatic field depends on:

- A. Only the endpoints, not the path taken
- B. The specific path taken between the points
- C. The total time taken to move the charge
- D. The velocity of the charge during motion

75. The phase velocity of an electromagnetic wave in free space is approximately:

- A. 3×10^6 m/s
- B. 3×10^{10} m/s
- C. 3×10^5 m/s
- D. 3×10^8 m/s

76. A quarter-wave transmission line section is often used to perform:

- A. Power amplification of the signal
- B. Impedance transformation (matching)
- C. Frequency multiplication of the carrier
- D. Rectification of the AC signal

77. In a feedback control system, the error signal is the difference between the:

- A. Reference input and the feedback signal
- B. Output signal and the disturbance input
- C. Forward gain and the feedback gain
- D. Open-loop and closed-loop transfer functions

78. A system that returns to equilibrium after a disturbance, with its output remaining bounded, is:

- A. Unstable
- B. Non-causal
- C. Stable
- D. Time-varying

79. The peak overshoot of a second-order system's step response depends primarily on its:

- A. Steady-state gain
- B. Damping ratio
- C. Input amplitude
- D. Number of zeros

80. An integral (I) control action is added to a loop primarily to:

- A. Increase the system's bandwidth substantially
- B. Add damping to reduce overshoot
- C. Speed up the initial transient response
- D. Eliminate the steady-state error

81. The Laplace-domain variable s in a transfer function corresponds, on the imaginary axis, to:

- A. The complex frequency, with $s = j\omega$ representing sinusoidal frequency
- B. The settling time of the step response
- C. The DC gain of the system
- D. The number of system poles

82. A unity-feedback system has its sensor in the:

- A. Forward path before the plant
- B. Reference input summing junction
- C. Feedback path with a gain of one
- D. Output disturbance channel

83. A system whose parameters do not change over time is described as:

- A. Nonlinear
- B. Stochastic
- C. Discrete
- D. Time-invariant

84. In digital communications, the baud rate refers to the number of:

- A. Bits transmitted per second
- B. Symbols transmitted per second
- C. Errors corrected per second
- D. Carrier cycles per second

85. Amplitude modulation places the message information in the carrier's:

- A. Envelope (amplitude variation)
- B. Instantaneous frequency
- C. Phase angle only
- D. Polarization direction

86. The primary disadvantage of increasing the transmission bandwidth of a system is:

- A. A reduction in the achievable data rate
- B. A decrease in the carrier frequency required
- C. More noise power admitted into the receiver
- D. The elimination of all signal distortion

87. A matched filter in a receiver is designed to maximize the:

- A. Transmitted carrier power
- B. Output signal-to-noise ratio at the sampling instant
- C. Bandwidth of the received signal
- D. Number of symbols per second

88. Code-division multiple access (CDMA) distinguishes users by assigning each a unique:

- A. Time slot in the frame
- B. Frequency band in the channel
- C. Carrier amplitude level
- D. Orthogonal spreading code

89. In the OSI model, encryption and data formatting are functions of the:

- A. Transport layer
- B. Network layer
- C. Presentation layer
- D. Physical layer

90. The transport-layer addressing element that identifies a specific application or service on a host is the:

- A. Port number
- B. MAC address
- C. IP address
- D. Subnet mask

91. A "packet" is the unit of data primarily associated with which OSI layer?

- A. Data link layer
- B. Network layer
- C. Transport layer
- D. Session layer

92. The maximum number of devices addressable on a network is determined by the:

- A. Speed of the network cabling
- B. Number of switches in the network
- C. Color coding of the connectors
- D. Number of bits in the address field

93. Convert the binary number 110 to decimal.

- A. 6
- B. 4
- C. 8
- D. 3

94. The Boolean expression $A + A'$ (A OR NOT A) always equals:

- A. A
- B. 0
- C. 1
- D. A'

95. An SR latch enters its forbidden (invalid) state when:

- A. Both S and R inputs are at logic 0
- B. $S = 1$ and $R = 0$
- C. $S = 0$ and $R = 1$
- D. Both S and R inputs are at logic 1

96. The number of bits in one nibble is:

- A. 8
- B. 4
- C. 2
- D. 16

97. A multiplexer is a digital circuit that:

- A. Selects one of several inputs to route to a single output
- B. Routes one input to several outputs simultaneously
- C. Stores multiple bits of data indefinitely
- D. Adds several binary numbers together

98. Converting the decimal number 7 to its 4-bit binary equivalent gives:

- A. 1110
- B. 0110
- C. 0111
- D. 1000

99. The primary advantage of using hexadecimal over binary for representing data is that hexadecimal is:

- A. Directly understood by the processor hardware
- B. More compact and easier for humans to read
- C. Capable of representing negative numbers only
- D. Faster for the computer to process internally

100. A ripple counter is also commonly known as a(n):

- A. Asynchronous counter
- B. Synchronous counter
- C. Ring counter
- D. Up-down counter

101. For the combinational logic circuit shown, what is the output F when $A = 0$ and $B = 1$?

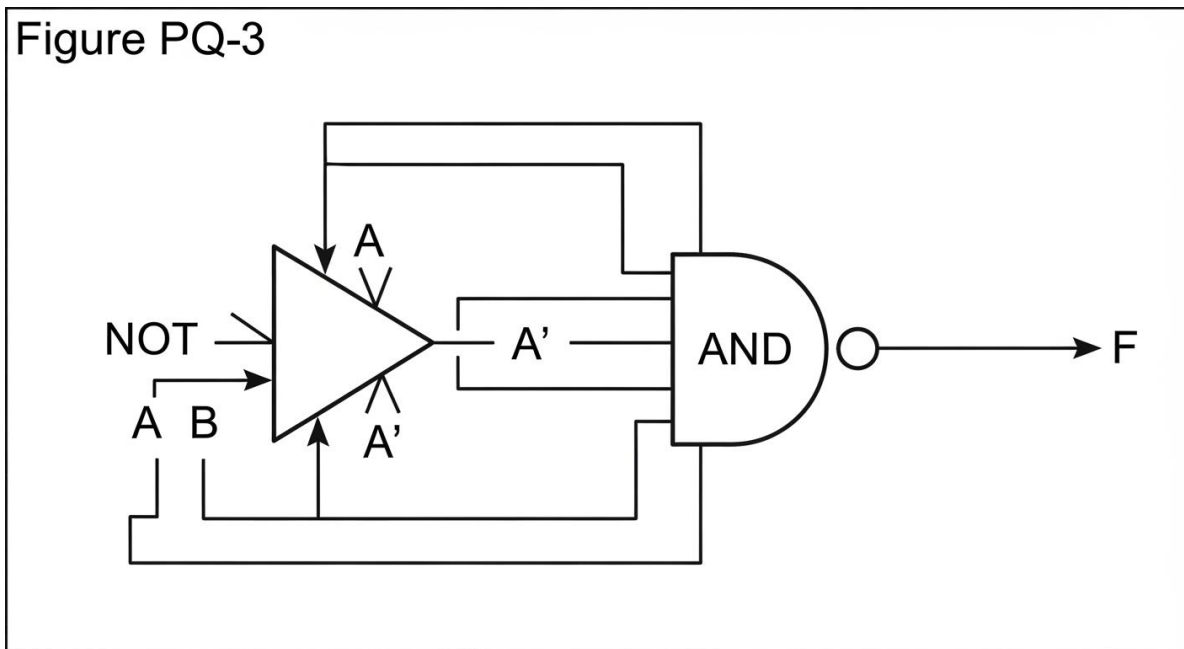

- A. 0
- B. Undefined
- C. High impedance
- D. 1

102. The component of the CPU that coordinates and sequences the fetching and executing of instructions is the:

- A. Arithmetic logic unit

- B. Cache memory
- C. Control unit
- D. Data bus

103. Read-only memory (ROM) is best described as memory that is:

- A. Volatile and erased when power is lost
- B. Non-volatile and retains data without power
- C. Faster than CPU registers in all cases
- D. Used only for temporary scratch storage

104. The "word size" of a processor primarily defines the:

- A. Number of bits processed as a unit in one operation
- B. Physical dimensions of the silicon chip
- C. Maximum clock frequency of the processor
- D. Number of cores integrated on the die

105. A page fault in a virtual memory system occurs when:

- A. The CPU clock signal is temporarily lost
- B. Two processes write to the same register
- C. A requested page is not currently in physical memory
- D. The cache and main memory hold different values

106. The throughput of a processor refers to the:

- A. Maximum voltage applied to the chip

- B. Physical width of the address bus
- C. Size of the largest cache level present
- D. Amount of work completed per unit time

107. In Big-O notation, an algorithm whose run time does not depend on the input size has complexity:

- A. $O(1)$
- B. $O(n)$
- C. $O(\log n)$
- D. $O(n^2)$

108. A "linked list" differs from an array in that its elements are:

- A. Stored in strictly contiguous memory locations
- B. Connected by pointers and need not be contiguous
- C. Limited to holding only numeric data types
- D. Accessed only by a fixed integer index

109. In software engineering, "debugging" is the process of:

- A. Writing the initial program specification
- B. Compiling the source code into machine code
- C. Designing the user interface layout
- D. Locating and removing defects in the code

110. A conditional statement (if-then) in a program is used to:

- A. Repeat a block of instructions many times

- B. Allocate a fixed block of memory
- C. Execute code only when a condition is met
- D. Define a reusable subroutine

PRACTICE EXAM 12 – ANSWER KEY AND FULL ANSWER EXPLANATIONS

- 1. C** — Applying the power rule term by term, $d/dx[5x^3 - 2x] = 15x^2 - 2$. Each term's exponent multiplies its coefficient and drops by one.
- 2. A** — By the power rule for integration, $\int x^3 dx = x^4/4 + C$. The exponent rises by one and divides the term.
- 3. D** — Since $j^2 = -1$, $j^3 = j^2 \cdot j = -j$. Powers of j cycle through $j, -1, -j, 1$ every four steps.
- 4. B** — Cosine equals zero at the odd multiples of 90° , which over $[0, 2\pi)$ are $\pi/2$ and $3\pi/2$. These are where the cosine curve crosses the axis.
- 5. C** — The determinant is $(1)(4) - (2)(3) = 4 - 6 = -2$. For a 2×2 matrix it is the main-diagonal product minus the off-diagonal product.
- 6. D** — By the chain rule, $d/dx[e^{(-x)}] = -e^{(-x)}$. The inner derivative of $-x$ contributes the negative sign.
- 7. A** — The decimal 0.75 equals $75/100$, which reduces to $3/4$. Dividing numerator and denominator by 25 gives lowest terms.
- 8. D** — The integral of $1/x$ is $\ln(x)$, so evaluating from 1 to e gives $\ln(e) - \ln(1) = 1 - 0 = 1$. This is the defining property of the natural logarithm's base.
- 9. D** — The angle is $\arctan(3/2) \approx 56.31^\circ$, measured from the positive x -axis. The ratio of the j -component to the i -component sets the direction.
- 10. C** — Both $\sin(30^\circ)$ and $\cos(60^\circ)$ equal 0.5, so their sum is 1. These are complementary-angle values that share the same magnitude.
- 11. A** — The radius of convergence describes the interval over which a power series converges. It does not apply to single terms or definite integrals.
- 12. C** — Using differentials, $dy = 6x \cdot dx = 6(2)(0.01) = 0.12$. The differential approximates the small change in y for a small change in x .

- 13. B** — The primes from 1 to 10 are 2, 3, 5, and 7, giving 4 of 10 outcomes, or $2/5$. Each numbered chip is equally likely to be drawn.
- 14. B** — With an even number of sorted values, the median is the average of the two middle ones: $(5 + 8)/2 = 6.5$. It lies between the central data points.
- 15. A** — An impossible event has probability 0, since it can never occur. Probabilities range from 0 for impossible to 1 for certain.
- 16. C** — The probability of no heads in two tosses is $(1/2)^2 = 1/4$, so at least one head has probability $1 - 1/4 = 3/4$. The complement simplifies the calculation.
- 17. D** — The expected value is the average of the equally likely outcomes 1 through 6, which is $(1 + 2 + \dots + 6)/6 = 3.5$. It need not be an attainable face value.
- 18. B** — An engineer's duty to protect client confidential information continues after the business relationship ends. Trade secrets and proprietary data remain protected over time.
- 19. A** — Using materials that violate the safety code endangers the public, so the engineer must refuse and require code-compliant materials. Client willingness to accept responsibility does not relieve this duty.
- 20. C** — Offering or accepting a bribe to obtain work is strictly prohibited as unethical under the NSPE Code. Disclosure or local custom does not make it acceptable.
- 21. B** — Prohibiting misrepresentation of fact upholds honesty and truthfulness, a core professional obligation. Engineers must present accurate information to clients and the public.
- 22. D** — By the Rule of 72, doubling time is $72/8 = 9$ years. This approximates the compounding period needed for money to double.
- 23. C** — Present worth is $1,000/(1 + 0.25) = 1,000/1.25 = \800 . Discounting the future amount by the rate gives its value today.
- 24. A** — The sinking fund factor (A/F) determines the uniform periodic deposit needed to reach a future sum. It distributes a future target across equal payments.
- 25. B** — A fixed cost remains constant regardless of production level, unlike a variable cost. Rent and equipment leases are typical fixed costs.
- 26. D** — The payback period is the time needed to recover the initial investment from net cash inflows. It measures how quickly capital is returned, not profitability.
- 27. A** — Annealing relieves internal lattice defects and stresses, reducing a conductor's resistivity. The improved crystal structure lets electrons move more freely.

- 28. C** — Silicon has four valence electrons, which allows it to form four covalent bonds in its crystal lattice. This tetravalent structure is the basis of its semiconductor behavior.
- 29. B** — Dielectric breakdown occurs when the applied field exceeds the material's dielectric strength, causing it to suddenly conduct. The insulator then fails destructively.
- 30. B** — Reluctance opposes magnetic flux just as resistance opposes electric current, making it the magnetic analog of resistance. Magnetomotive force drives flux through reluctance much like voltage drives current.
- 31. D** — Parallel resistance is $(20 \times 30)/(20 + 30) = 600/50 = 12 \Omega$. The equivalent is less than the smaller of the two resistors.
- 32. C** — Inductor energy is $\frac{1}{2}LI^2 = \frac{1}{2} \times 2 \times 3^2 = 9 \text{ J}$. Stored energy grows with the square of the current.
- 33. A** — In DC steady state a fully charged capacitor passes no current and acts as an open circuit. It blocks direct current once charged.
- 34. B** — Power is $I^2R = 2^2 \times 5 = 20 \text{ W}$, and energy is power times time: $20 \times 10 = 200 \text{ J}$. Energy accumulates as power delivered over the interval.
- 35. D** — The two parallel 10Ω resistors give 5Ω , which adds in series with the 5Ω resistor for a total of 10Ω . Parallel branches combine before the series element.
- 36. A** — A phasor represents a sinusoid by its magnitude and phase at a single operating frequency. This simplifies AC analysis to algebra with complex numbers.
- 37. C** — The Thévenin voltage equals the open-circuit terminal voltage, $V = I \times R = 1 \times 10 = 10 \text{ V}$. The full source current flows through the resistor when the terminals are open.
- 38. D** — Susceptance is the imaginary part of admittance, the reciprocal of impedance. It describes how readily a reactive element passes AC current.
- 39. B** — Two equal capacitors in series give $C/2$, since series capacitance is the product over the sum. Series connection reduces total capacitance.
- 40. C** — The RMS value of a sinusoid is the peak divided by $\sqrt{2}$: $5/1.414 \approx 3.54 \text{ A}$. This is the equivalent heating value of the AC current.
- 41. C** — In a pure resistor the voltage and current are exactly in phase, since the resistor introduces no reactance. Their ratio is simply the resistance at all times.
- 42. B** — A charging RC circuit reaches about 99% of its final value after roughly five time constants. Each time constant the remaining gap shrinks by about 63%.

- 43. A** — From $P = I^2R$, the current is $\sqrt{(P/R)} = \sqrt{(24/6)} = \sqrt{4} = 2$ A. This relates dissipated power to current and resistance.
- 44. D** — The Laplace transform of $f'(t)$ with zero initial conditions is $s \cdot F(s)$. Differentiation in time corresponds to multiplication by s .
- 45. C** — A system with all poles in the left half of the s -plane is stable, since each pole contributes a decaying response. Negative real parts ensure the output settles.
- 46. A** — Convolution in the time domain becomes multiplication in the frequency domain. This transform property greatly simplifies system analysis.
- 47. B** — The discrete unit step $u[n]$ equals 1 for $n \geq 0$ and 0 for negative n . It marks the turning-on of a discrete-time signal.
- 48. D** — The Nyquist criterion requires sampling faster than twice the highest signal frequency to avoid aliasing. Sampling below this rate causes frequency folding.
- 49. C** — A filter's order sets how steeply its response rolls off near the cutoff frequency. Higher-order filters approach the ideal brick-wall response more closely.
- 50. B** — A causal system cannot respond before an input arrives, so its impulse response is zero for $t < 0$. Causality is required for real-time realizability.
- 51. A** — A symmetric square wave contains the fundamental and only odd harmonics, with no even harmonics. The Fourier series of such a wave has terms at odd multiples of the fundamental.
- 52. D** — A digital signal processor handles signals that are discrete in both time (sampled) and amplitude (quantized). This dual discretization defines a digital signal.
- 53. B** — A first-order low-pass filter responds to a step input with an exponential rise toward the final value. The time constant sets how quickly it approaches steady state.
- 54. C** — The magnitude of the frequency response gives the gain applied to a sinusoid at that frequency. The phase response separately describes the introduced phase shift.
- 55. A** — Systems connected in parallel add their transfer functions, since their outputs sum for a common input. This contrasts with the product rule for cascaded systems.
- 56. D** — In a non-inverting amplifier the input signal is applied directly to the non-inverting (+) input. Feedback returns to the inverting input to set the gain.
- 57. C** — Reverse biasing a p-n junction pulls carriers away from the junction, widening the depletion region. This increases the junction's blocking ability.

- 58. B** — A Zener diode operated in reverse breakdown holds a stable voltage, serving as a voltage reference or regulator. Its sharp breakdown characteristic provides the regulation.
- 59. A** — The common-base current gain alpha is slightly less than 1, since the collector current is a little smaller than the emitter current. The small base current accounts for the difference.
- 60. D** — An ideal diode in forward conduction acts as a short circuit with zero voltage drop. It offers no opposition to forward current in the ideal model.
- 61. B** — The slew rate sets the maximum rate at which the op-amp's output voltage can change. Exceeding it distorts fast or large-amplitude output signals.
- 62. C** — Fan-out is the number of gate inputs that a single output can reliably drive. Exceeding it degrades the logic levels at the driven inputs.
- 63. A** — The marked Q-point sits at $I_C = 2.5$ mA on the load line. The quiescent collector current is read directly from the operating point's vertical coordinate.
- 64. D** — The turns ratio equals the voltage ratio: $2,400/240 = 10$, or 10:1. The higher-voltage primary has ten times the turns of the secondary.
- 65. B** — A purely reactive load consumes zero real (average) power, exchanging energy without dissipating it. Only reactive power flows in such a load.
- 66. A** — Three-phase systems deliver constant total power and use conductor material more efficiently than single-phase. This makes them the standard for power distribution.
- 67. C** — Synchronous speed is $120f/P = 120 \times 60/2 = 3,600$ rpm. A two-pole machine runs fastest for a given frequency.
- 68. D** — The service factor indicates the continuous overload a motor can sustain beyond its rated power. A 1.15 service factor, for example, allows 15% overload.
- 69. A** — Interchanging any two of the three supply lines reverses the rotating field, and thus the rotation, of a three-phase induction motor. This reverses the phase sequence seen by the stator.
- 70. B** — Apparent power is $S = P/\text{pf} = 5/0.8 = 6.25$ kVA. The power factor relates real power to the total apparent power.
- 71. D** — A circuit breaker interrupts fault currents to protect equipment and wiring from damage. It automatically opens the circuit under overload or short-circuit conditions.
- 72. C** — An over-excited synchronous motor draws leading current and thus supplies reactive power to the grid. This lets it act as a synchronous condenser for power-factor correction.

- 73. B** — In a linear medium, $B = \mu H$, relating flux density to field intensity through the permeability. This constitutive relation underlies magnetic circuit analysis.
- 74. A** — In an electrostatic (conservative) field, the work to move a charge depends only on the endpoints, not the path. This path-independence is what allows a potential to be defined.
- 75. D** — Electromagnetic waves travel at about 3×10^8 m/s in free space, the speed of light. This constant relates a wave's frequency and wavelength.
- 76. B** — A quarter-wave line transforms impedance, matching a load to a source by its characteristic-impedance relationship. This impedance inversion is widely used in RF matching.
- 77. A** — The error signal is formed by subtracting the feedback signal from the reference input. The controller acts to drive this error toward zero.
- 78. C** — A system that returns to equilibrium with a bounded output after a disturbance is stable. Stability ensures the response does not grow without limit.
- 79. B** — The peak overshoot of a second-order step response is governed by the damping ratio, with lower damping giving larger overshoot. It is independent of input amplitude for a linear system.
- 80. D** — Integral control accumulates past error and drives the steady-state error to zero. It eliminates the residual offset that proportional control alone leaves.
- 81. A** — The Laplace variable s is the complex frequency, and on the imaginary axis $s = j\omega$ corresponds to sinusoidal frequency. This connects the transfer function to the frequency response.
- 82. C** — A unity-feedback system feeds the output back through a gain of one to the summing junction. The output is thus compared directly with the reference.
- 83. D** — A system whose parameters remain constant over time is time-invariant. Its response to an input does not depend on when the input is applied.
- 84. B** — The baud rate is the number of symbols transmitted per second, which may differ from the bit rate. Each symbol can carry multiple bits in higher-order schemes.
- 85. A** — In amplitude modulation, the message varies the amplitude (envelope) of the carrier. The information is recovered by detecting that envelope.
- 86. C** — A wider receiver bandwidth admits more noise power, degrading the signal-to-noise ratio. Bandwidth must balance data rate against noise.
- 87. B** — A matched filter maximizes the output signal-to-noise ratio at the sampling instant, giving the best detection performance in white noise. It is correlated to the transmitted pulse shape.

- 88. D** — CDMA assigns each user a unique orthogonal spreading code, letting many users share the same frequency and time. The codes allow the receiver to separate the overlapping signals.
- 89. C** — The presentation layer handles data formatting, encryption, and translation between representations. It prepares application data for transmission.
- 90. A** — The port number identifies a specific application or service on a host at the transport layer. It directs incoming data to the correct process.
- 91. B** — The packet is the data unit associated with the network layer, which handles routing. Lower layers use frames and higher layers use segments.
- 92. D** — The number of bits in the address field sets how many unique devices can be addressed. More address bits exponentially increase the addressable count.
- 93. A** — Binary 110 equals $4 + 2 + 0 = 6$ in decimal. Summing the weighted powers of two gives the value.
- 94. C** — The Boolean sum $A + A'$ is always 1, since either a variable or its complement must be true. This is the complement law for OR.
- 95. D** — An SR latch's forbidden state occurs when both S and R are 1, which drives both outputs to the same level and gives an undefined result on release. This combination is therefore disallowed.
- 96. B** — A nibble consists of four bits, exactly half of an 8-bit byte. One hexadecimal digit represents one nibble.
- 97. A** — A multiplexer routes one of several inputs, chosen by select lines, to a single output. It performs many-to-one data selection.
- 98. C** — Decimal 7 is $4 + 2 + 1$, which is 0111 in four bits. The three low-order bits are set and the high bit is zero.
- 99. B** — Hexadecimal is more compact and human-readable than binary, with each digit representing four bits. This makes long binary values easier to write and interpret.
- 100. A** — A ripple counter is an asynchronous counter, because each flip-flop is clocked by the previous stage's output rather than a common clock. This causes a cumulative propagation delay.
- 101. D** — The NOT gate inverts $A = 0$ to 1, and the AND of that 1 with $B = 1$ gives $F = 1$. Both AND inputs are high, so the output is high.
- 102. C** — The control unit coordinates and sequences the fetch and execute operations of the processor. It directs data flow among the CPU components.

103. B — ROM is non-volatile memory that retains its contents without power. It typically holds firmware and boot code.

104. A — Word size is the number of bits a processor handles as a single unit in one operation. It influences the processor's data path and register width.

105. C — A page fault occurs when a requested memory page is not currently in physical RAM and must be loaded from disk. The operating system then retrieves the page into memory.

106. D — Throughput measures the amount of work a processor completes per unit time. It reflects overall performance, not just clock speed.

107. A — An algorithm whose run time is independent of input size has $O(1)$, or constant, complexity. Its execution time does not grow as the data grows.

108. B — A linked list connects its elements with pointers, so they need not occupy contiguous memory. This allows flexible insertion and deletion without shifting elements.

109. D — Debugging is the process of locating and removing defects from program code. It follows testing, which reveals that defects exist.

110. C — A conditional (if-then) statement executes a block of code only when its condition is true. It provides decision-making control flow in a program.